



ELJEN TECHNOLOGY



Organic Scintillators Product Catalog

TABLE OF CONTENTS

About Us	1
Plastic Scintillators	3
General Description	
Product Description	
Wavelength Shifters	21
Plastic Fibers	25
Light Guides and Acrylic Plastic	27
Liquid Scintillators	28
General Description	
Product Descriptions	
Liquid Scintillator Cells	
Neutron Detection	38
Fast Neutron Detector	
Thermal Neutron Detectors	
Zinc Sulfide Coated Sheets and Discs	42
Accessories and Detector Assembly Materials	46
Optical Coupling Materials	
Reflective Paint	
Wrapping Materials	
Storage and Handling of Plastic Scintillators	51
Storage and Handling of Liquid Scintillators	52
Machining and Polishing of Plastic Scintillators	53
Structural Properties of Plastic Scintillator	54
Plastic Scintillator Response Curves	55
Product Applications and Commercial Equivalents	61

ABOUT ELJEN TECHNOLOGY

Eljen Technology has been providing organic scintillators and detector assemblies to research and commercial customers worldwide since 1997. Based in Sweetwater, Texas, Eljen Technology has become one of the leaders in the development of organic scintillation material and one of the largest manufacturers in the world, with core personnel boasting over 50 years of in-depth experience.

Founded on the principle that customers deserve a high level of service, support, and quality, we strive to provide scintillation products of the highest possible standards to satisfy our customers' needs. Our products include plastic scintillators, liquid scintillators, wavelength shifting plastics, light guides, and accessories for assembling scintillation detectors. All of our products are manufactured in-house to ensure the best quality for our customers. Most of our products are supplied based on customer requirements and can be supplied with custom designs. If the products identified in this catalog do not meet your specific requirements, please contact us and let us know how we can help you.

Customer service is our watchword, and we'll be glad to assist you in any way possible. If the products identified in this catalog do not meet your specific requirements, please let us know how we can help you.

Sweetwater is located in west central Texas, approximately 40 miles (60 km) to the west of Abilene and 220 miles (354 km) to the west of Dallas. Sweetwater is an oasis with "sweet" tasting water amid bitter-tasting gypsum streams. The Kiowa named the original site "Mobeetie", their word for "sweet water".



OUR FACILITIES

Eljen Technology is comprised of five separate buildings in Sweetwater, TX, having total manufacturing facilities of over 60,000 sq. ft. (5570 m²). Our main manufacturing facility located at 1300 W Broadway (pictured below) is over 42,000 sq. ft. (3900 m²).



OVENS

Eljen has sixteen processing ovens:

- Twelve with 17 ft. (5.2 m) long capacity
- Four with 10 ft. (3 m) long capacity

MACHINERY

- Six Bed Mills - ranging from 1.8 m to 4.5 m travel
- CNC Lathe with live tooling
- CNC Summit Lathe
- Two CNC Hurco Mills
- Two Lathes with 2.4 m bed



PLASTIC SCINTILLATORS

Eljen Technology's plastic scintillators are based on a plastic matrix of polyvinyltoluene and fluors necessary to give each plastic scintillator its unique properties. Our plastic scintillators are available in a variety of different geometries, including cast sheets, blocks, rods, cylinders, thin films, and annuli. Custom sizes and geometries are available for most of these products. All plastic scintillators are cut to customer specified dimensions and machined to ensure the best optical properties on all surfaces.

Custom plastic scintillator detector assemblies are also available. Such assemblies generally include acrylic light-guides, light-tight wrapping, and one or more photomultiplier tube assemblies (includes photomultiplier tube, voltage divider, Mu-shielding and light-tight housing).



The tables below list typical cast sheet and pressed sheet sizes. Please contact Eljen Technology regarding your specific requirements.

CAST SHEET SIZES		
Thickness (mm)	Thickness Tolerance (mm)	Sheet Size (cm)
5	+ 0.56 / - 0.46	60 × 101
6.4	+ 0.64 / - 0.51	60 × 101
10	± 0.51	60 × 203
12.7	± 0.64	60 × 203
15	± 0.70	60 × 203
20	± 0.73	60 × 203
25	± 0.75	60 × 203
38	± 0.90	60 × 203
50	± 2.0	60 × 203
75	± 2.5	60 × 101
100	± 3.8	60 × 101
125	± 6	60 × 101
150	± 6	60 × 101

THIN FILM SHEET SIZES		
Thickness (mm)	Thickness Tolerance (%)	Sheet Size (mm)
0.1	± 25	150 × 150
0.25	± 15	200 × 200
	± 20	250 × 250
0.5	± 10	200 × 200
	± 15	250 × 250
1.0	± 7.5	200 × 200
	± 10	500 × 500
1.5	± 5	200 × 200
	± 7.5	500 × 500
2.0	± 4	200 × 200
	± 7.5	500 × 500
3.0	± 4	200 × 200
	± 5	500 × 500

THIN FILM MATERIALS
EJ-200
EJ-204
EJ-212
EJ-228
EJ-230
EJ-232
EJ-240
EJ-260
EJ-264
EJ-280

GENERAL PURPOSE

EJ-200, EJ-204, EJ-208, EJ-212

These scintillators have the properties of long optical attenuation length and fast timing with an emission spectrum well matched to common photomultiplier tubes.

EJ-200 combines the two important properties of long optical attenuation length and fast timing which make it particularly useful for time-of-flight systems using scintillators greater than one meter long. It is the detector of choice for many industrial applications, such as gauging and environmental protection, where high sensitivity and signal uniformity are critical operating requirements.

EJ-204 has the highest scintillation efficiency of any of Eljen's plastic scintillators, along with the combination of high speed and good attenuation length. It is particularly well suited for high-performance detector systems for nuclear and high-energy physics research. Its emission wavelength near 400 nm couples ideally with bi-alkali photomultiplier tubes while still being long enough to be effectively used with UVT light guides.

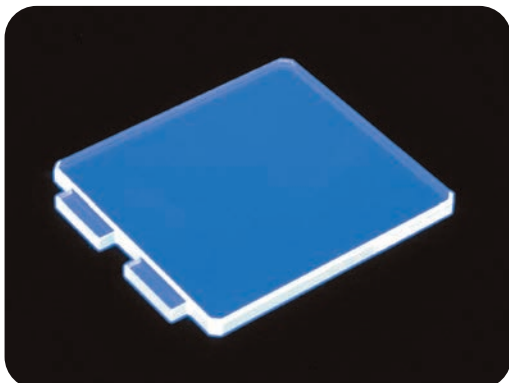
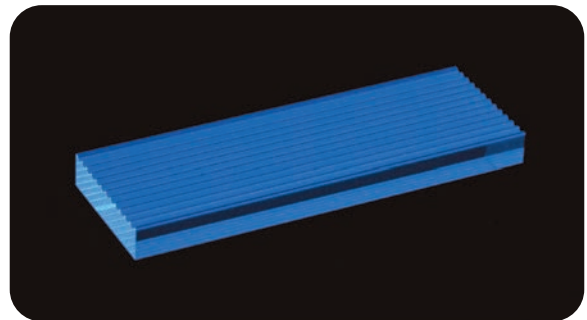
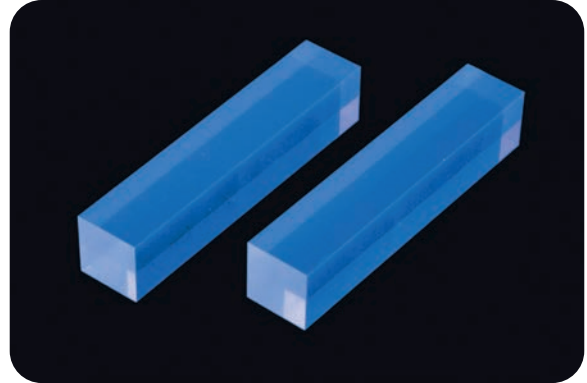

EJ-208 possesses the longest wavelength emission of commonly available blue scintillators and hence should be considered for applications requiring complex or extended light guides. The long emission spectrum provides additional resistance to radiation damage of which the most common symptom is increased optical attenuation at short wavelengths. It is intended specifically for use in large sizes where timing is of secondary importance and uniformity of light collection is paramount.

EJ-212 is a scintillator specially formulated for use in thin sheets (thickness less than 5 mm), but it can also be used in thick cast sheet, rods and ingots. Applications include industrial and health physics measurement of alpha, beta, gamma, and neutron radiation as well as in numerous medical instruments and scientific research ranging from low background shields in nuclear physics to space-borne astrophysics systems. It is best utilized in sizes up to 100 cm long. EJ-200 should be considered for longer pieces.

PROPERTIES	EJ-200	EJ-204	EJ-208	EJ-212
Light Output (% Anthracene)	64	68	60	65
Scintillation Efficiency (photons/1 MeV e ⁻)	10,000	10,400	9,200	10,000
Wavelength of Maximum Emission (nm)	425	408	435	423
Light Attenuation Length (cm)	380	160	400	250
Rise Time (ns)	0.9	0.7	1.0	0.9
Decay Time (ns)	2.1	1.8	3.3	2.4
Pulse Width, FWHM (ns)	2.5	2.2	4.2	2.7
H Atoms per cm ³ (×10 ²²)	5.17	5.15	5.17	5.17
C Atoms per cm ³ (×10 ²²)	4.69	4.68	4.69	4.69
Electrons per cm ³ (×10 ²³)	3.33	3.33	3.33	3.33
Density (g/cm ³)	1.023	1.023	1.023	1.023

Polymer Base: Polyvinyltoluene
Refractive Index: 1.58
Softening Point: 75°C
Vapor Pressure: Vacuum-compatible
Coefficient of Linear Expansion:
 7.8×10^{-5} below 67°C
Temperature Range: -60°C to 60°C
Light Output (L.O.) vs. Temperature:
 At 60°C, L.O. = 95% of that at 20°C
 No change from -60°C to 20°C

Chemical Compatibility:
Attacked By: Aromatic solvents, Chlorinated solvents, Ketones, Solvent bonding cements, etc.
Stable In: Water, Dilute acids and alkalis, Lower alcohols, Silicone greases.
 It is safe to use most epoxies with these scintillators.

EJ-200 EMISSION SPECTRUM

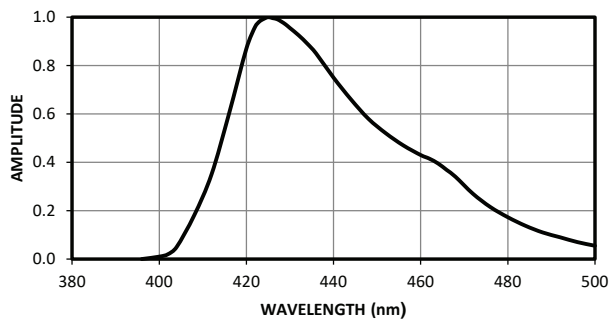

EJ-204 EMISSION SPECTRUM

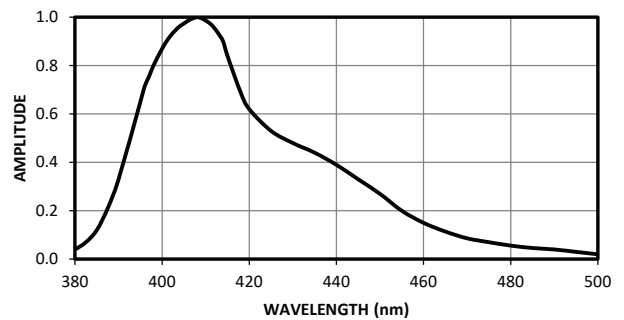

EJ-208 EMISSION SPECTRUM

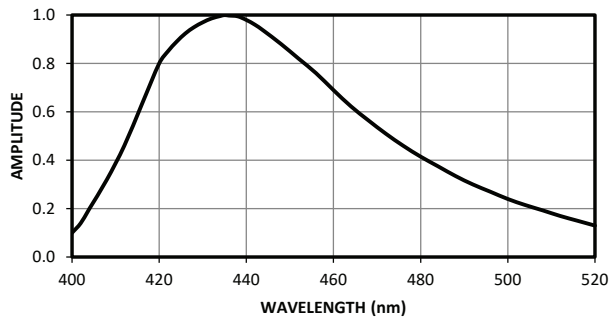

EJ-212 EMISSION SPECTRUM

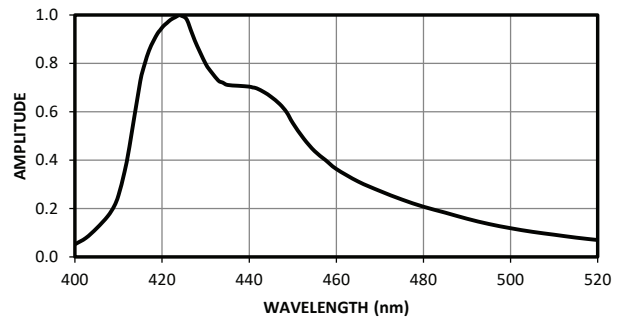

Note:
 See page 52 for structural properties of plastic scintillator.
 See pages 53-57 for plastic scintillator response curves.

ULTRA-THIN FILM EJ-214

Formerly known as EJ-299-07, this special plastic scintillator has been formulated specifically for use in ultra-thin films employed for heavy ion studies and beam monitors. The formula contains a very high concentration of the waveshifting dopant to efficiently absorb and shift the primary scintillation light, which is in the UV range. The plastic base is PVT, and the films are suitable for use in high vacuum. They may be mounted to light guides with optical epoxies or silicone greases. Cleaning is best done with isopropyl alcohol.

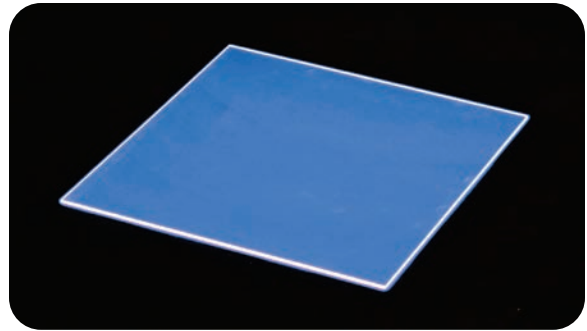

PROPERTIES	EJ-214
Scintillation Efficiency (photons/1 MeV e ⁻)	9,000
Wavelength of Maximum Emission (nm)	435
Decay Time (ns)	2
H Atoms per cm ³ (×10 ²²)	5.18
C Atoms per cm ³ (×10 ²²)	4.67
N Atoms per cm ³ (×10 ¹⁹)	4.89
O Atoms per cm ³ (×10 ¹⁹)	2.59
Electrons per cm ³ (×10 ²³)	3.27
Density (g/cm ³)	1.02
Softening Point (°C)	60

AVAILABLE SIZES	
Thickness	25 ± 7.5 μm
Maximum Tile Size	100 mm × 100 mm

Note: Only offered with rectangular dimensions. Discs not offered.

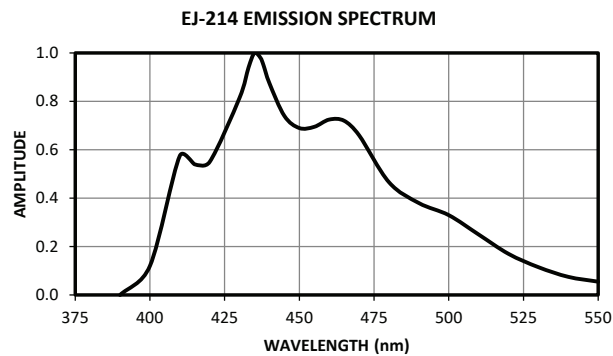

FAST TIMING

EJ-228, EJ-230

These plastic scintillators are intended for very fast timing applications or when very high pulse pair resolution is required. The use of light guides is best avoided.

EJ-228 should be used in small sizes for the best timing results, with the largest scintillator dimension less than 10 cm to minimize photon scattering effects. This scintillator is particularly useful where very high count rates are present.

EJ-230 is a variant on the optimized EJ-228 formula for applications where a detector dimension must exceed 10 cm. The mean free path of the scintillation emission spectrum is typically 100 cm. Scintillators up to 50 cm can be employed with good timing and light collection results. This scintillator is particularly useful where very high count rates are present.

PROPERTIES	EJ-228	EJ-230
Light Output (% Anthracene)	67	64
Scintillation Efficiency (photons/1 MeV e ⁻)	10,200	9,700
Wavelength of Maximum Emission (nm)	391	391
Light Attenuation Length (cm)	-	120
Rise Time (ns)	0.5	0.5
Decay Time (ns)	1.4	1.5
Pulse Width, FWHM (ns)	1.2	1.3
H Atoms per cm ³ (×10 ²²)	5.15	5.15
C Atoms per cm ³ (×10 ²²)	4.69	4.69
Electrons per cm ³ (×10 ²³)	3.33	3.33
Density (g/cm ³)	1.023	1.023

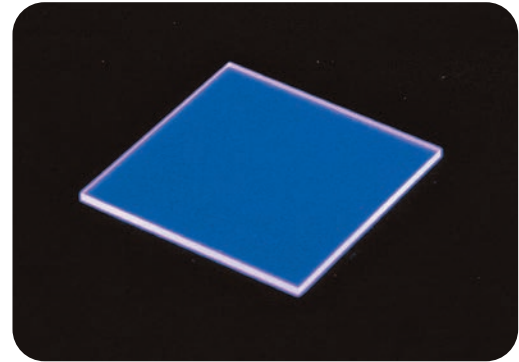

Polymer Base: Polyvinyltoluene

Refractive Index: 1.58

Softening Point: 75°C

Vapor Pressure: Vacuum-compatible

Coefficient of Linear Expansion:

7.8×10^{-5} below 67°C

Temperature Range: -60°C to 60°C

Light Output (L.O.) vs. Temperature:

At 60°C, L.O. = 95% of that at 20°C

No change from -60°C to 20°C

Chemical Compatibility:

Attacked By: Aromatic solvents, Chlorinated solvents, Ketones, Solvent bonding cements, etc.

Stable In: Water, Dilute acids and alkalis, Lower alcohols, Silicone greases.

It is safe to use most epoxies with these scintillators.

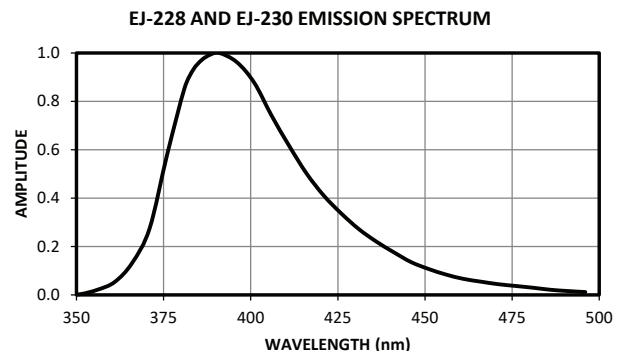

FAST TIMING

EJ-232, EJ-232Q

EJ-232 plastic scintillator is intended for very fast timing applications or when very high pulse pair resolution is required. Due to the small emission wavelength, the optical mean free path of this scintillator is approximately 10 cm. Therefore, to achieve the best light collection and to optimize the timing performance, EJ-232 should be used in a small size with the largest scintillator dimension less than 10 cm to minimize photon scattering effects. The use of light guides is best avoided.

EJ-232Q plastic scintillator is a quenched variant of EJ-232 specifically formulated for ultra-fast counting applications. The introduction of small amounts of benzophenone to EJ-232 significantly shortens the timing properties for purposes of achieving very high counting rates or improved coincidence timing. The quenching does not affect the

emission spectrum but does reduce the scintillation efficiency (see table below). While it is recommended to keep the scintillator size and shape small in order to achieve the best timing performance, it is not recommended to use EJ-232Q in thin films (thicknesses ≤ 3 mm) due to the vapor pressure of benzophenone.



PROPERTIES	EJ-232	EJ-232Q (% BENZOPHENONE)				
		0.5	1.0	2.0	3.0	5.0
Light Output (% Anthracene)	55	19	11	5	4	3
Scintillation Efficiency (photons/1 MeV e ⁻)	8,400	2,900	1,700	770	610	460
Wavelength of Maximum Emission (nm)	370	370	370	370	370	370
Rise Time (ps)	350	110	105	100	100	100
Decay Time (ps)	1,600	700	700	700	700	700
Pulse Width, FWHM (ps)	1,300	360	290	260	240	220
H Atoms per cm ³ ($\times 10^{22}$)	5.13	5.12	5.12	5.12	5.12	5.12
C Atoms per cm ³ ($\times 10^{22}$)	4.66	4.66	4.66	4.66	4.66	4.66
Electrons per cm ³ ($\times 10^{23}$)	3.30	3.38	3.38	3.38	3.38	3.38
Density (g/cm ³)	1.023	1.023	1.023	1.023	1.023	1.023

Polymer Base: Polyvinyltoluene

Refractive Index: 1.58

Softening Point: 75°C

Vapor Pressure: Vacuum-compatible

Coefficient of Linear Expansion:

7.8×10^{-5} below 67°C

Temperature Range: -60°C to 60°C

Light Output (L.O.) vs. Temperature:

At 60°C, L.O. = 95% of that at 20°C

No change from -60°C to 20°C

Chemical Compatibility:

Attacked By: Aromatic solvents, Chlorinated solvents, Ketones, Solvent bonding cements, etc.

Stable In: Water, Dilute acids and alkalis, Lower alcohols, Silicone greases.

It is safe to use most epoxies with these scintillators.

EJ-232 AND EJ-232Q EMISSION SPECTRUM

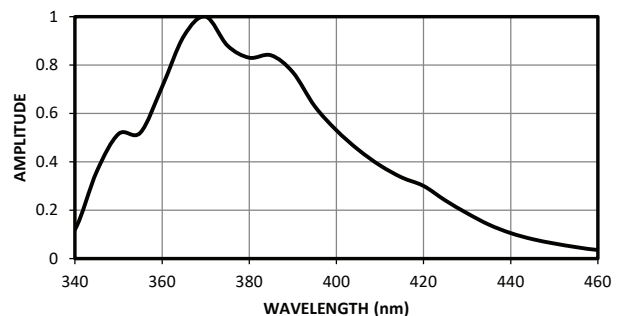

LONG DECAY TIME EJ-240

This plastic scintillator has an unusually long principal decay time, 285 ns. Its primary application is to be used in combination with standard organic scintillators having typical decay times near 2 ns. Such “phoswich” detectors are usually constructed with the fast and slow scintillators combined to form one optical element viewed by a single photomultiplier with pulse shape discrimination electronics employed to identify the different pulses. The fast front scintillator is usually relatively thin providing dE/dX

information, while the slow rear scintillator is relatively thick to provide the full energy signal. Although the PMT is mounted on the surface of the slow scintillator, the pulse from the fast scintillator is easily identified since it undergoes little degradation while passing through the slow scintillator.

EJ-240G, a green emitting variant, is also available with the emission maximum at 490 nm.

PROPERTIES	EJ-240
Light Output (% Anthracene)	41
Scintillation Efficiency (photons/1 MeV e ⁻)	6,300
Wavelength of Maximum Emission (nm)	430
Light Attenuation Length (cm)	240
Rise Time (ns)	19.5
Decay Time (ns)	285
H Atoms per cm ³ (×10 ²²)	5.19
C Atoms per cm ³ (×10 ²²)	4.68
Electrons per cm ³ (×10 ²³)	3.33
Density (g/cm ³)	1.023

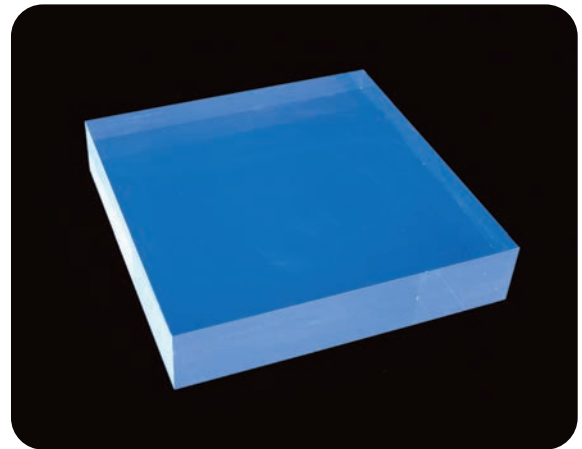

Polymer Base: Polyvinyltoluene

Refractive Index: 1.58

Softening Point: 75°C

Vapor Pressure: Vacuum-compatible

Coefficient of Linear Expansion:

7.8 × 10⁻⁵ below 67°C

Temperature Range: -60°C to 60°C

Light Output (L.O.) vs. Temperature:

At 60°C, L.O. = 95% of that at 20°C

No change from -60°C to 20°C

Chemical Compatibility:

Attacked By: Aromatic solvents, Chlorinated solvents, Ketones, Solvent bonding cements, etc.

Stable In: Water, Dilute acids and alkalis, Lower alcohols, Silicone greases.

It is safe to use most epoxies with this scintillator.

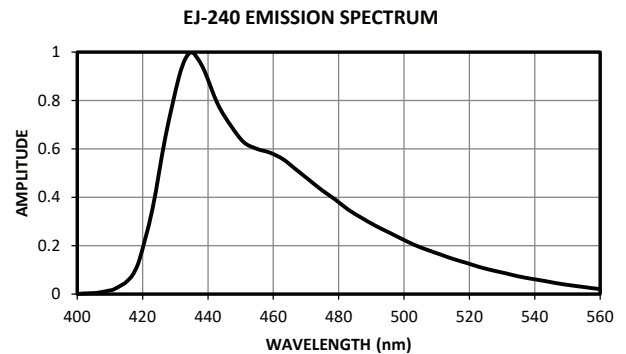

HIGH TEMPERATURE

EJ-244, EJ-248, EJ-244M, EJ-248M

EJ-244 and **EJ-248** are respective analogs of the popular EJ-208 and EJ-200, possessing their long optical attenuation length and overall superior scintillation properties while being able to be used at somewhat higher temperatures. While both EJ-208 and EJ-200 have softening points near 70°C, these plastics have softening temperatures at 99°C. These higher temperature characteristics have been achieved by using a specially modified variant of the conventional PVT base plastic. Hence, they have the temperature characteristic of polystyrene-based plastics while not suffering the lower scintillation efficiencies associated with polystyrene. These plastics are also mechanically more robust, more easily machined and more resistant to scratching than the conventional PVT-based materials.

EJ-244M and **EJ-248M** are respective analogs of EJ-244 and EJ-248 with the additional property of the base polymer being crosslinked. The thermal softening point, 99°C, and the scintillation properties of these plastics are the same as for the standard EJ-244 and EJ-248. Crosslinking can be helpful when the plastic scintillator may be used for extended periods at temperatures which clearly exceed the softening point. In such cases, the plastic will soften but, because of the crosslinking, will not flow or undergo a major change in shape. These plastics are best used only in compact physical forms such as small cylinders or blocks.

While intended for higher temperature applications, these scintillators are optimized for use where the scintillator will experience only short intervals at elevated temperatures. These scintillators have been additionally fortified against the accelerated yellowing that occurs with any organic polymer when operated at elevated temperatures; however, continuous use at elevated temperatures will shorten the overall lifetime of the scintillator. To maximize the scintillator lifetime for continued use at elevated temperatures, extra care should be taken to eliminate or minimize the presence of air in the scintillator housings.

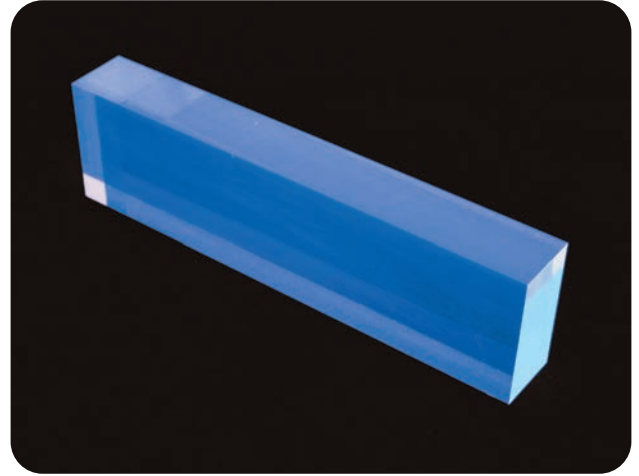

PROPERTIES	EJ-244	EJ-248	EJ-244M	EJ-248M
Light Output (% Anthracene)	56	60	56	60
Scintillation Efficiency (photons/1 MeV e ⁻)	8,600	9,200	8,600	9,200
Wavelength of Maximum Emission (nm)	434	425	434	425
Light Attenuation Length (cm)	270	250	270	250
Rise Time (ns)	1.0	0.9	1.0	0.9
Decay Time (ns)	3.3	2.1	3.3	2.1
Pulse Width, FWHM (ns)	4.2	2.5	4.2	2.5
H Atoms per cm ³ (×10 ²²)	5.18	5.18	5.18	5.18
C Atoms per cm ³ (×10 ²²)	4.69	4.69	4.69	4.69
Electrons per cm ³ (×10 ²³)	3.34	3.34	3.34	3.34
Density (g/cm ³)	1.023	1.023	1.023	1.023

Polymer Base: Polyvinyltoluene

Refractive Index: 1.58

Softening Point: 99°C

Vapor Pressure: Vacuum-compatible

Coefficient of Linear Expansion:

7.8 × 10⁻⁵ below 70°C

Temperature Range: -60°C to 90°C

(For optimum long term performance, do not use at temperatures exceeding 60°C for extended periods of time)

Light Output (L.O.) vs. Temperature:

At 60°C, L.O. = 95% of that at 20°C

At 90°C, L.O. = 87% of that at 20°C

No change from -60°C to 20°C

Chemical Compatibility:

Attacked By: Aromatic solvents, Chlorinated solvents, Ketones, Solvent bonding cements, etc.

Stable In: Water, Dilute acids and alkalis, Lower alcohols, Silicone greases.

It is safe to use most epoxies with these scintillators.

EJ-244 AND EJ-244M EMISSION SPECTRUM

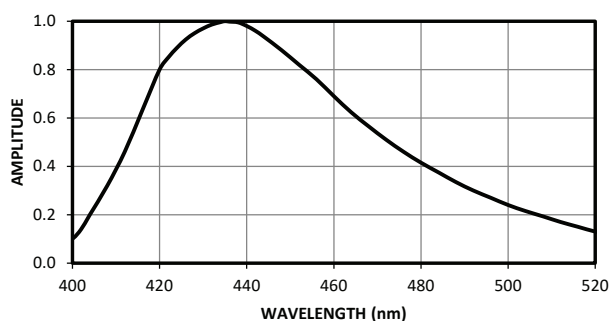

EJ-248 AND EJ-248M EMISSION SPECTRUM

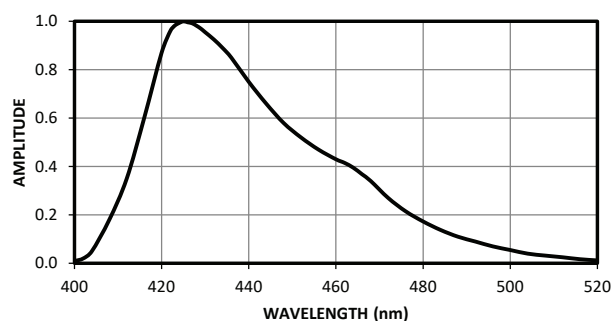

BORON LOADED EJ-254

This blue-emitting plastic scintillator contains natural boron at concentrations up to 5% by weight. It is a clear, stable plastic with physical properties similar to those of the standard Eljen plastic scintillators. Its principal applications are fast neutron spectrometry and thermal neutron detection. The primary function of the boron is to provide a unique scintillation signal for low energy neutrons. The standard formulation contains 5% boron, and practical boron concentrations down to 1% are available.

The isotopic fraction of ^{10}B in natural boron is 19.9%, meaning that the 5% loaded plastic contains nearly 1% of

^{10}B . The neutron capture reaction on the boron $^{10}\text{B}(n,\alpha)^7\text{Li}$ has a Q value of 2.78 MeV of which 2.34 MeV is shared by the alpha and lithium particles. This energy is fully captured in the plastic to produce a scintillation signal approximately equivalent in amplitude to that of a 76 keV electron. For delayed coincidence timing of the capture of fast neutrons, the time delay from the prompt recoil-proton pulse is typically 2.7 μs for 5% B-nat plastics. This delay is inversely proportional to the boron loading.

Reference: D. M. Drake et al., Nucl. Instr. & Meth., A247, 576-582 (1986)

PROPERTIES	EJ-254 (% boron)		
	5%	2.5%	1%
Light Output (% Anthracene)	48	56	60
Scintillation Efficiency (photons/1 MeV e ⁻)	7,500	8,600	9,200
Wavelength of Maximum Emission (nm)	425	425	425
Rise Time (ns)	0.85	0.85	0.85
Decay Time (ns)	1.51	1.51	1.51
Pulse Width, FWHM (ns)	2.24	2.24	2.24
H Atoms per cm ³ ($\times 10^{22}$)	5.18	5.17	5.16
C Atoms per cm ³ ($\times 10^{22}$)	4.44	4.55	4.62
^{10}B Atoms per cm ³ ($\times 10^{20}$)	5.68	2.83	1.14
Electrons per cm ³ ($\times 10^{23}$)	3.33	3.33	3.33
Density (g/cm ³)	1.026	1.023	1.021



Polymer Base: Polyvinyltoluene

Refractive Index: 1.58

Softening Point: 75°C

Vapor Pressure: Vacuum-compatible

Coefficient of Linear Expansion:

7.8×10^{-5} below 67°C

Temperature Range: -60°C to 60°C

Light Output (L.O.) vs. Temperature:

At 60°C, L.O. = 95% of that at 20°C

No change from -60°C to 20°C

Chemical Compatibility:

Attacked By: Aromatic solvents, Chlorinated solvents, Ketones, Solvent bonding cements, etc.

Stable In: Water, Dilute acids and alkalis, Lower alcohols, Silicone greases.

It is safe to use most epoxies with this scintillator.

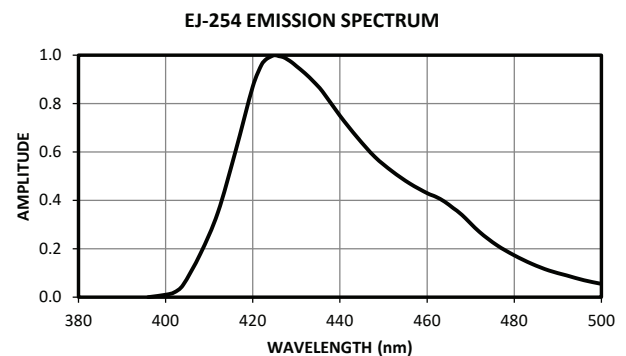

LEAD LOADED EJ-256

EJ-256 is a homogeneous, clear plastic scintillator in which lead has been incorporated by means of organometallic chemistry. Typical lead loading ranges from 1% to 5% by weight. Loadings up to 10% have been made but are not recommended. With increasing lead loading, there are corresponding losses in scintillation efficiency and optical clarity of the final plastic.

EJ-256 is best used for gamma detection at energies below 100 keV where there is a significant impact of the lead on attenuation coefficients. This is most strongly evident at

60 keV and lower where the photoelectric cross section is notably enhanced. At these energies, signal amplitudes from EJ-256 are commonly greater than those from an intrinsically brighter plastic scintillator that has no loading with heavy atoms as a result of the photoelectric contribution in the detection process. Detection efficiencies are also notably increased.

EJ-256 is also excellent for dosimetric detection applications. Lead concentrations in the 1-2% range impart a flatness in response down to at least 20 keV.

PROPERTIES	EJ-256 (% lead)	
	5%	1.5%
Light Output (% Anthracene)	34	50
Scintillation Efficiency (photons/1 MeV e ⁻)	5,200	7,700
Wavelength of Maximum Emission (nm)	425	425
Decay Time (ns)	2.1	2.1
H Atoms per cm³ (×10 ²²)	5.20	5.21
C Atoms per cm³ (×10 ²²)	4.62	4.68
Electrons per cm³ (×10 ²³)	3.48	3.39
Density (g/cm ³)	1.081	1.037



Polymer Base: Polyvinyltoluene

Refractive Index: 1.58

Softening Point: 75°C

Vapor Pressure: Vacuum-compatible

Coefficient of Linear Expansion:

7.8×10^{-5} below 67°C

Temperature Range: -60°C to 60°C

Light Output (L.O.) vs. Temperature:

At 60°C, L.O. = 95% of that at 20°C

No change from -60°C to 20°C

Chemical Compatibility:

Attacked By: Aromatic solvents, Chlorinated solvents, Ketones, Solvent bonding cements, etc.

Stable In: Water, Dilute acids and alkalis, Lower alcohols, Silicone greases.

It is safe to use most epoxies with this scintillator.

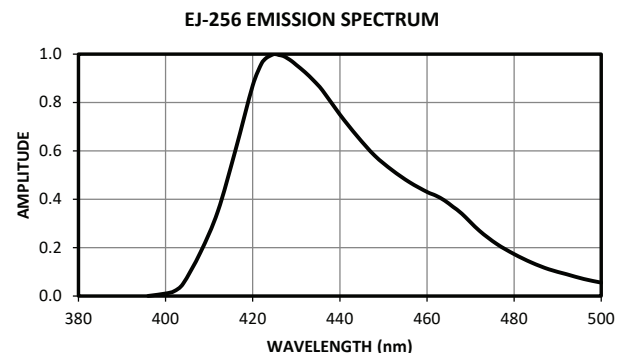

**GAMMA ATTENUATION OF EJ-256 LEAD-LOADED
PLASTIC SCINTILLATORS COMPARED TO WATER
RATIO OF LINEAR ATTENUATION COEFFICIENTS**

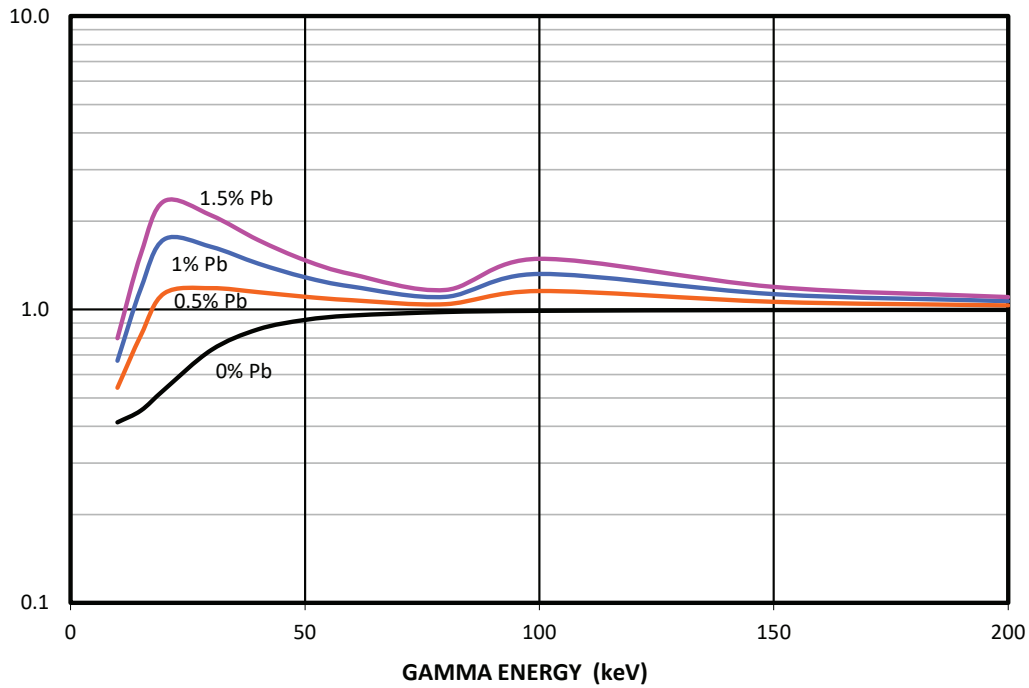

PHYSICAL CONSTANTS						
% Lead	5%	2%	1.5%	1%	0.5%	0%
L.O. (% Anthracene)	34	47	50	53	56	65
S.E. (photons/1 MeV e ⁻)	5,200	7,300	7,700	8,100	8,600	10,000
Density (g/cm ³)	1.081	1.043	1.037	1.033	1.028	1.023

LINEAR ATTENUATION COEFFICIENTS (μ)						
keV	5%	2%	1.5%	1%	0.5%	0%
10	8.95	4.75	4.07	3.41	2.76	2.10
15	6.56	2.96	2.38	1.82	1.26	0.70
20	4.93	2.14	2.69	1.25	0.820	0.385
30	1.80	0.843	0.688	0.538	0.389	0.239
40	0.932	0.485	0.413	0.344	0.275	0.205
50	0.591	0.345	0.306	0.267	0.229	0.191
60	0.428	0.277	0.253	0.230	0.207	0.183
80	0.287	0.216	0.205	0.194	0.183	0.172
100	0.452	0.275	0.246	0.219	0.191	0.164
150	0.251	0.187	0.177	0.167	0.157	0.147
200	0.186	0.155	0.150	0.145	0.140	0.135
600	0.096	0.092	0.091	0.090	0.090	0.085
660	0.0914	0.0876	0.0870	0.0865	0.0860	0.0855
1250	0.0664	0.0642	0.0638	0.0636	0.0633	0.0630

GREEN EMITTING EJ-260, EJ-262

These plastic scintillators have been formulated for use where longer wavelengths are needed for efficient optical coupling to solid-state photosensors. Because of their longer emission wavelengths, they will exhibit somewhat greater radiation hardness than conventional blue plastic scintillators. Both scintillators can be used to detect the same kinds of radiation commonly measured with blue scintillators.

EJ-260 is a green emitting plastic scintillator that has been formulated for use where longer wavelengths are advantageous for purposes of light piping. The green

fluorescence is of short enough wavelength and the scintillation efficiency is high enough for successful use with conventional blue sensitive photomultiplier tubes. The light output data presented in the table were determined with a flat response photodetector and would be approximately one half that level for a typical bialkali photomultiplier tube.

EJ-262 is also a green emitting scintillator, but has a faster decay time and a shorter maximum emission wavelength than those of EJ-260. The shorter emission wavelength makes EJ-262 suitable for use with blue sensitive photomultiplier tubes.

PROPERTIES	EJ-260	EJ-262
Light Output (% Anthracene)	60	57
Scintillation Efficiency (photons/1 MeV e ⁻)	9,200	8,700
Wavelength of Maximum Emission (nm)	490	481
Light Attenuation Length (cm)	350	250
Rise Time (ns)	~1.5	0.9
Decay Time (ns)	9.2	2.1
H Atoms per cm ³ (×10 ²²)	5.21	5.20
C Atoms per cm ³ (×10 ²²)	4.70	4.69
Electrons per cm ³ (×10 ²³)	3.35	3.33
Density (g/cm ³)	1.023	1.023

Polymer Base: Polyvinyltoluene

Refractive Index: 1.58

Softening Point: 75°C

Vapor Pressure: Vacuum-compatible

Coefficient of Linear Expansion:

7.8×10^{-5} below 67°C

Temperature Range: -60°C to 60°C

Light Output (L.O.) vs. Temperature:

At 60°C, L.O. = 95% of that at 20°C

No change from -60°C to 20°C

Chemical Compatibility:

Attacked By: Aromatic solvents, Chlorinated solvents, Ketones, Solvent bonding cements, etc.

Stable In: Water, Dilute acids and alkalis, Lower alcohols, Silicone greases.

It is safe to use most epoxies with these scintillators.

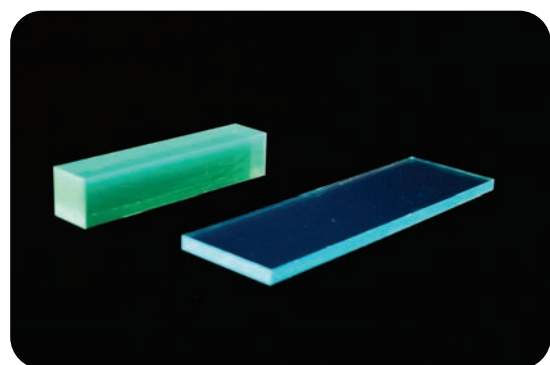

EJ-260 EMISSION SPECTRUM

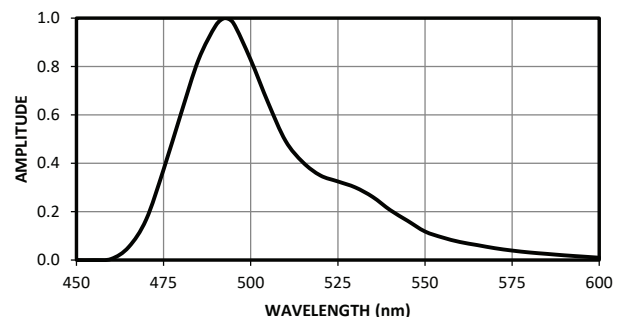

EJ-262 EMISSION SPECTRUM

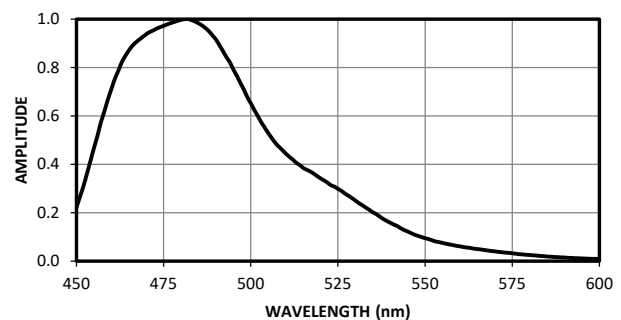

⁶LITHIUM LOADED PULSE-SHAPE DISCRIMINATION EJ-270

This plastic scintillator contains the element Lithium-6 at an isotopic enrichment of 95.5+ atom%. It is also formulated to provide classical pulse shape discrimination (PSD) for identification of scintillation pulses from fast neutrons, gammas and thermal neutrons. It is presently available as cylinders up to 60 mm diameter x 60 mm long and cubes up to 51 mm per side. At this time, EJ-270 is available with a ⁶Li loading level of 0.5% by weight. Initial performance information of the Eljen product is presented on the next page. This information is from a presentation at the 2016 SPIE Conference by permission from Lawrence Livermore National Laboratory (LLNL) where the scintillator was invented. [Cherepy, N.J., Martinez, H.P., Sanner, R.D., Beck, P.R., Drury, O.B., Swanberg, E.L., Payne, S.A., Hurlbut, C.R., & Morris, B. (2017). New Plastic Scintillators for Gamma Spectroscopy, Neutron Detection and Imaging. 2017 IEEE Nuclear Science Symposium and Medical Imaging Conference (NSS/MIC), 1-3.]



PROPERTIES	EJ-270
Light Output (% Anthracene)	31
Scintillation Efficiency (photons/1 MeV e ⁻)	4,800
Electron Energy Equivalence of n-Capture Peak (keV)	350
Wavelength of Max. Emission (nm)	425
Rise Time (ns)	TBD
Decay Time (ns)	TBD
Pulse Width, FWHM (ns)	TBD
No. of H atoms per cm ³ (×10 ²²)	4.74
No. of C atoms per cm ³ (×10 ²²)	4.55
No. of ⁶ Li atoms per cm ³ (×10 ²⁰)	5.75
No. of O atoms per cm ³ (×10 ²¹)	4.79
No. of N atoms per cm ³ (×10 ²⁰)	9.31
No. of Electrons per cm ³ (×10 ²³)	3.67
Density (g/cm ³)	1.14

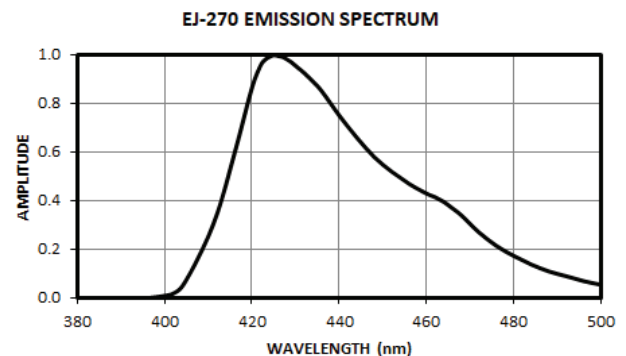

Chemical Compatibility:

Attacked By: Aromatic solvents, Chlorinated solvents, Ketones, Solvent bonding cements, etc.

Stable In: Water, Dilute acids and alkalis, Lower alcohols, Silicone greases.

Compatible with most epoxies and “super glues”.

Eljen ⁶Li loaded PSD Plastics 2"x1.5"

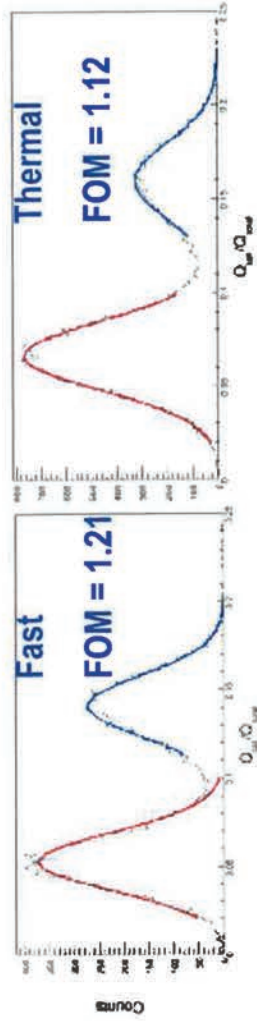
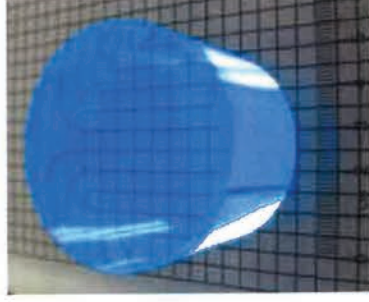
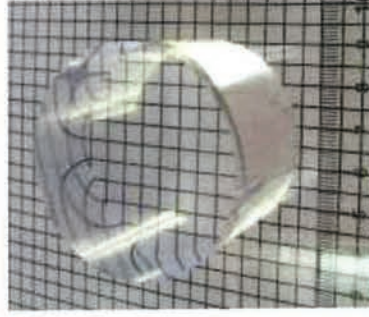
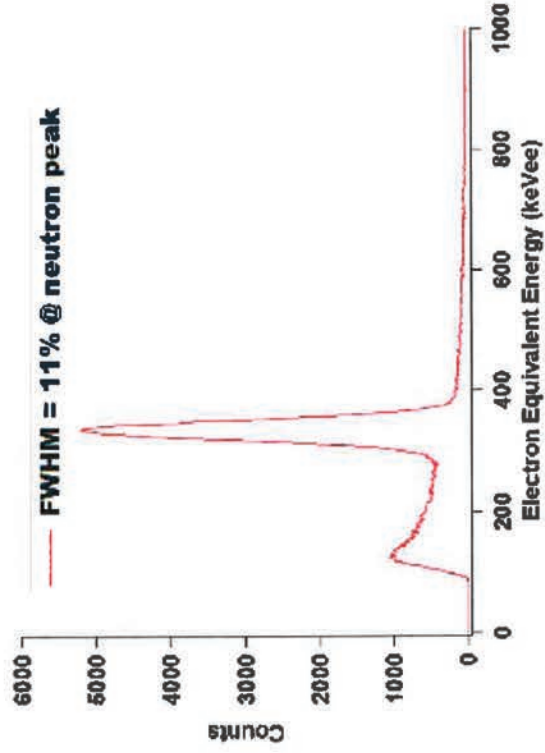
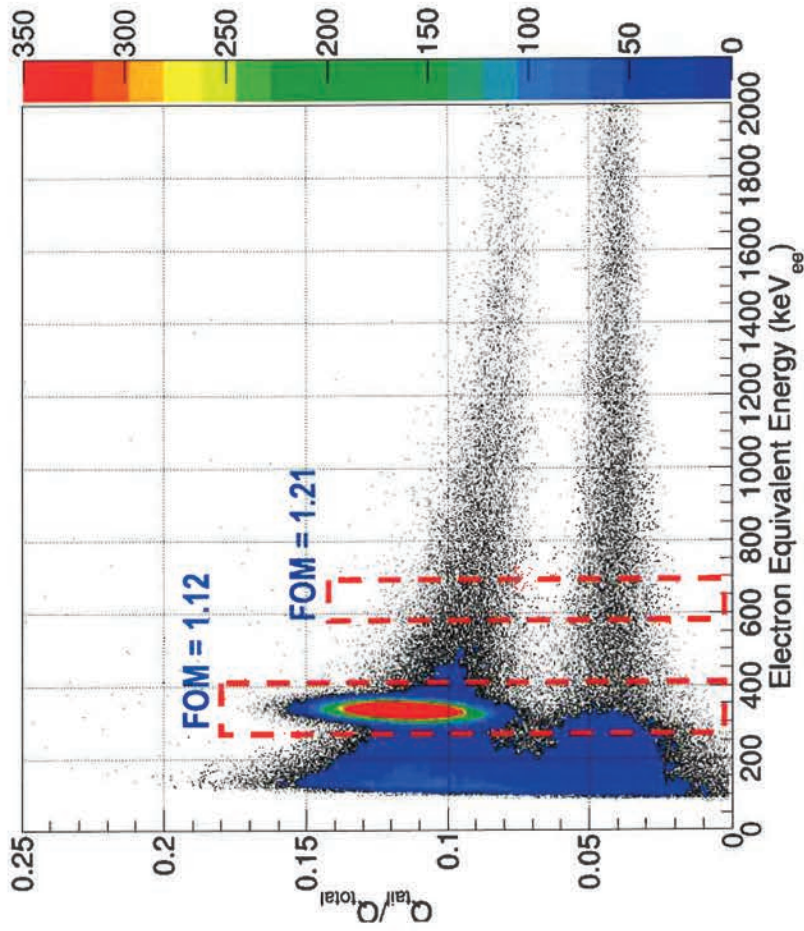

Lawrence Livermore National Laboratory



PULSE-SHAPE DISCRIMINATION EJ-276D

EJ-276D pulse-shape discriminating plastic scintillator enables the separation of gamma and fast neutron signals on the basis of their timing characteristics. This scintillator replaces all versions of EJ-276, EJ-299-33, and EJ-299-34 PSD scintillators and embodies the following improvements:

- Non-hygroscopic
- Excellent physical hardness, equal to or superior to that of standard plastic scintillators
- Long-term stability of scintillation and optical characteristics
- Basic PSD properties increased to being comparable to the best liquid scintillators

EJ-276G with green fluorescence is also available for use with solid state sensors.

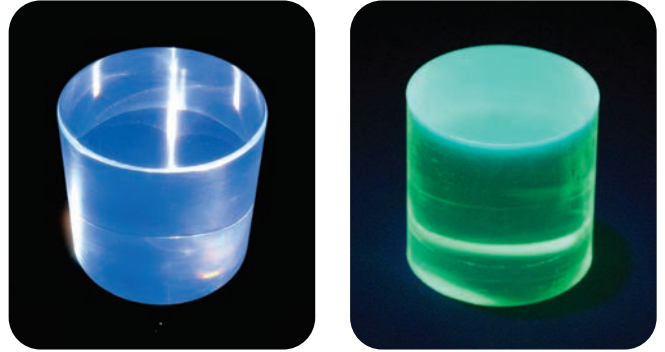

PROPERTIES		EJ-276D	EJ-276G
Light Output (% Anthracene)		56	52
Scintillation Efficiency (photons/1 MeV e ⁻)		8,600	8,000
Wavelength of Maximum Emission (nm)		425	490
H Atoms per cm ³ (×10 ²²)		4.647	4.647
C Atoms per cm ³ (×10 ²²)		4.944	4.944
Electrons per cm ³ (×10 ²³)		3.545	3.545
Density (g/cm ³)		1.099	1.099
Approx. Mean Decay Times of First 3 Components (ns)	Gamma Excitation	13, 35, 270	—
	Neutron Excitation	13, 50, 460	—

Chemical Compatibility:

Attacked By: Aromatic solvents, Chlorinated solvents, Ketones, Solvent bonding cements, etc.

Stable In: Water, Dilute acids and alkalis, Lower alcohols, Silicone greases.

It is safe to use most epoxies with this scintillator.

Available Sizes

Cylinders up to 127 mm diameter x 200 mm long and plates up to 25 mm thick x 250 mm x 250 mm can be supplied.

PSD SCATTER CHART, AmBe

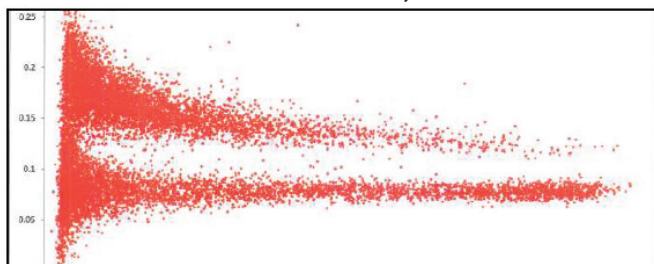

SCINTILLATOR SIZE: 127 mm DIA × 51 mm THICK

EJ-276D & EJ-276G EMISSION SPECTRUM

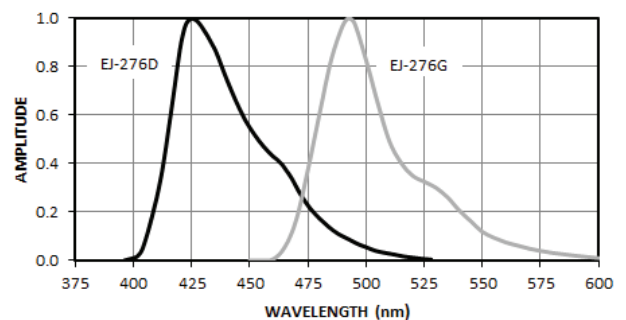

CASTING RESIN

EJ-290

EJ-290 is a partially-polymerized plastic scintillator formulated for final curing in the user's facilities at a relatively low temperature. It is supplied in a kit form consisting primarily of the scintillator resin and a polymerization initiator. Upon combining the ingredients using the provided instructions, a solid plastic scintillator can be made at a relatively low polymerization temperature. The final scintillation and physical properties are similar to those of the conventional blue emitting plastic scintillator EJ-212.

Please see our website for instructions on how to use EJ-290. Typical shelf life for this product is approximately 6 months when stored under recommended conditions.



PROPERTIES	EJ-290
Light Output (% Anthracene)	58
Scintillation Efficiency (photons/1 MeV e ⁻)	9,000
Wavelength of Maximum Emission (nm)	423
Decay Time (ns)	~ 3
H Atoms per cm ³ (×10 ²²)	5.17
C Atoms per cm ³ (×10 ²²)	4.67
Electrons per cm ³ (×10 ²³)	3.33
Density (g/cm ³)	1.023

Polymer Base: Polyvinyltoluene
Refractive Index: 1.58
Softening Point: 75°C
Vapor Pressure: Vacuum-compatible
Coefficient of Linear Expansion:
 7.8×10^{-5} below 67°C

PACKAGE SIZES
500 mL
1000 mL

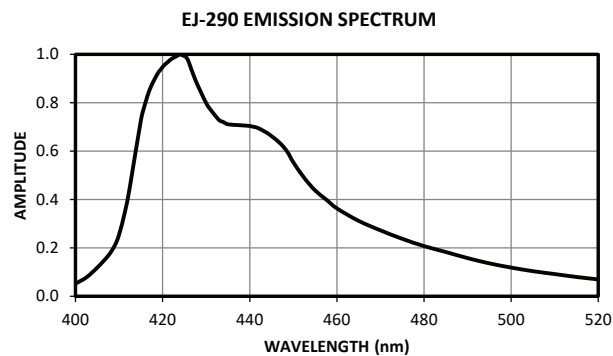

PLASTIC SCINTILLATOR PAINT

EJ-296

EJ-296 is a solution of plastic scintillator materials dissolved in a xylene solvent to form a paint for fabricating ultra-thin films or for applying directly to a customer's support surface. Scintillator films as thin as 0.1 μm can be made by forming the films on a water surface. Spin casting techniques have also been used successfully to form films of well controlled thickness. EJ-296 is a moderately viscous solution which may be applied as received. For making thinner films, the paint can be thinned with additional solvent.

The fluor system of EJ-296 has been formulated specifically for the fabrication of thin films with two specific considerations in mind: (1) Vacuum compatibility and (2) maximum shifting of the primary scintillation light in thin films. Because the base solvent is xylene, care should be taken in handling and storing EJ-296 with regard to potential flammability. Always work in a well ventilated area.

PROPERTIES	EJ-296
Light Output (% Anthracene)	60
Scintillation Efficiency (photons/1 MeV e^-)	9,000
Wavelength of Maximum Emission (nm)	435
Rise Time (ns)	~ 1.0
Decay Time (ns)	~ 2.5
Pulse Width, FWHM (ns)	~ 3.5
H Atoms per cm^3 ($\times 10^{22}$)	5.17
C Atoms per cm^3 ($\times 10^{22}$)	4.69
Electrons per cm^3 ($\times 10^{23}$)	3.33
Density (g/cm^3)	1.02



Polymer Base: Polyvinyltoluene
Refractive Index: 1.58
Softening Point: 75°C
Vapor Pressure: Vacuum-compatible
Coefficient of Linear Expansion:
 7.8×10^{-5} below 67°C
Temperature Range: -60°C to 60°C
Light Output (L.O.) vs. Temperature:
 At 60°C, L.O. = 95% of that at 20°C
 No change from -60°C to 20°C

Chemical Compatibility:
Attacked By: Aromatic solvents, Chlorinated solvents, Ketones, Solvent bonding cements, etc.
Stable In: Water, Dilute acids and alkalis, Lower alcohols, Silicone greases.
 It is safe to use most epoxies with this scintillator.

PACKAGE SIZES
400 mL
800 mL
2.5 L
5 L

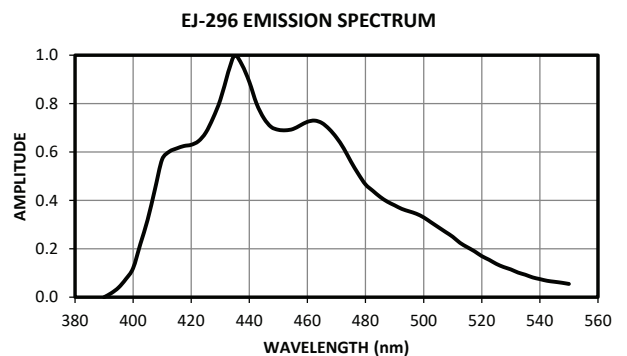

WAVELENGTH SHIFTING MATERIALS

Eljen Technology offers a select range of wavelength shifting materials that absorb light at one wavelength and re-emit the light isotropically at longer wavelengths to provide useful modes of light collection. Four PVT based wavelength shifting plastics and two wavelength shifting paints used to make thin films are available.



WAVELENGTH SHIFTING PLASTICS

EJ-280, EJ-282, EJ-284, EJ-286

Four wavelength shifting (WLS) plastics are available. All are normally based on PVT but can also be provided based on PVT variants providing higher temperature characteristics. These products are also available in custom formulations. Please contact us regarding your specific requirements.

EJ-280 is a green-emitting WLS plastic ideal for shifting the emission spectra of common blue scintillators. It is commonly used in the form of long narrow bars air-coupled to blue scintillators arrayed either in flat planes or in stacks. The bars provide a compact means of light collection. The green light is effectively turned 90° as a result of the isotropic re-emission and is transmitted by total internal reflection to photomultiplier tubes at both ends of the bar to achieve highly uniform light collection. While there is a typical 75% loss of signal amplitude in these systems, they can provide advantages over conventional light collection methods. Although not indicated in the spectrum on the following

page, EJ-280 has also been shown to be particularly good for shifting wavelengths below 200 nm.

EJ-282 is a green-emitting WLS plastic similar to EJ-280 but with a slightly shorter maximum emission wavelength making it suitable for use with blue-sensitive photomultiplier tubes.

EJ-284 is a red-emitting WLS plastic ideal for shifting green-emitting scintillators such as CsI(Tl) into the red. There is also a useful absorption maximum in the blue, as indicated in the spectrum on the following page.

EJ-286 is a blue-emitting WLS plastic with strong broad absorbance in the near-UV and formerly known as EJ-299-27. It is formulated to reduce the scintillation response by a factor exceeding 100x.

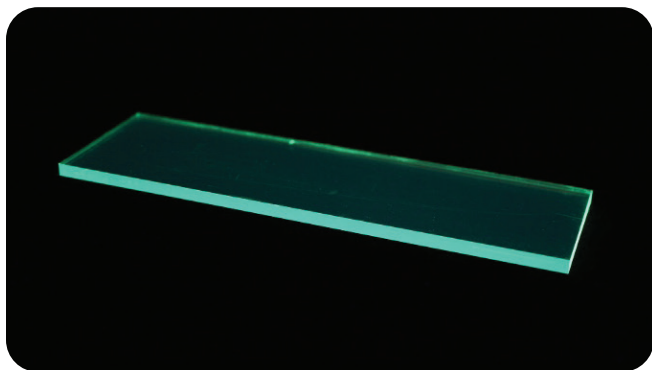

EJ-280

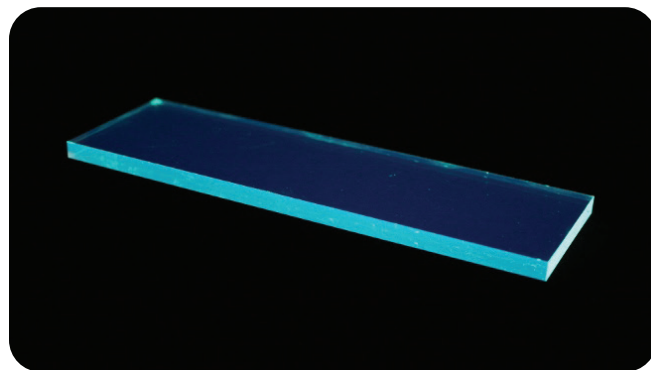

EJ-282

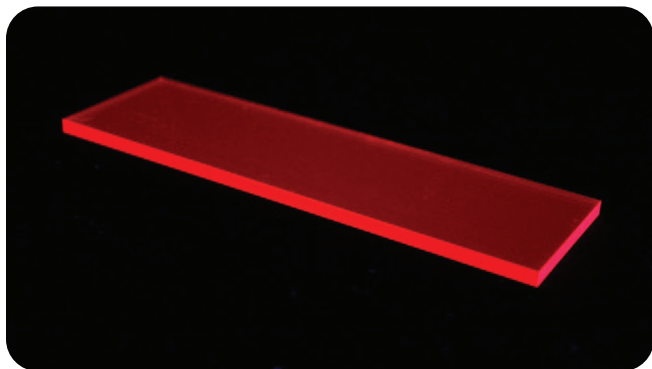

EJ-284

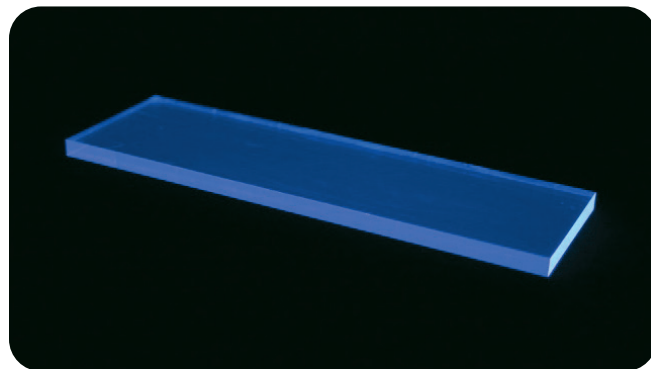

EJ-286

PROPERTIES	EJ-280	EJ-282	EJ-284	EJ-286
Wavelength of Maximum Emission (nm)	490	481	608	425
Wavelength of Maximum Absorption (nm)	427	390	574	355
Decay Time (ns)	8.5	1.9	13	1.2
Quantum Efficiency (%)	86	93	95	92
Density (g/cm ³)	1.023	1.023	1.023	1.023

Polymer Base: Polyvinyltoluene
Refractive Index: 1.58
Softening Point: 75°C
Vapor Pressure: Vacuum-compatible
Coefficient of Linear Expansion:
 7.8×10^{-5} below 67°C

Chemical Compatibility:

Attacked By: Aromatic solvents, Chlorinated solvents, Ketones, Solvent bonding cements, etc.

Stable In: Water, Dilute acids and alkalis, Lower alcohols, Silicone greases.

It is safe to use most epoxies with these plastics.

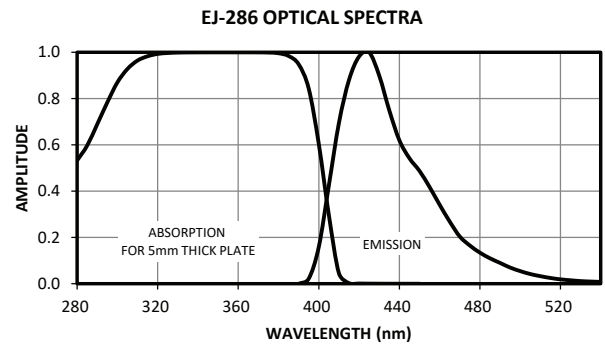
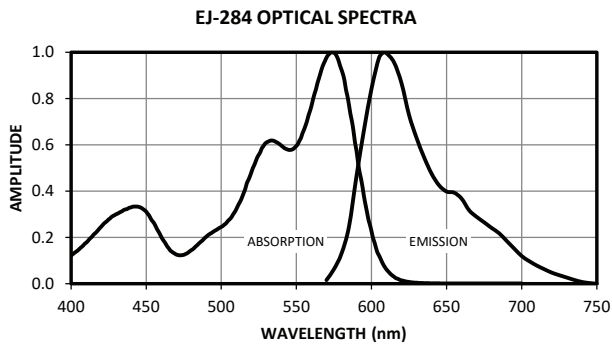
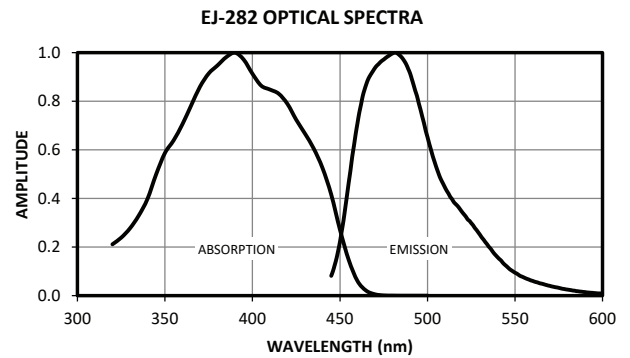
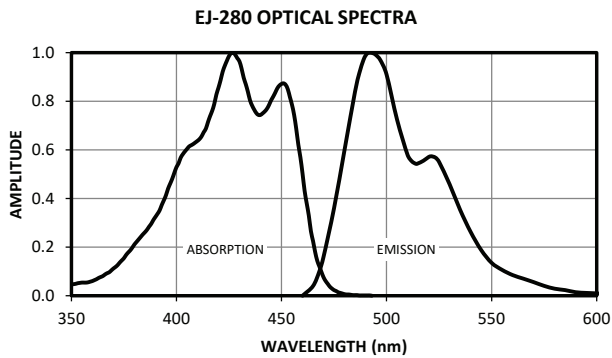

WAVELENGTH SHIFTING PAINT

EJ-298, EJ-298G

EJ-298 is a blue-emitting wavelength shifting paint, and **EJ-298G** is a green emitting wavelength shifting paint. These paints consist of a polyvinyltoluene (PVT) binder and fluorescent dopants dissolved in a xylene solvent. Each paint is nominally 20% solids by weight, and one liter will cover approximately 3.3 square meters with a film 50 μm (0.002 in) thick.

EJ-298 and EJ-298G may be applied to clean glass plates by brushing or by a draw-bar technique to produce a clear film. Adhesion is best when the painted substrate is well cleaned so as to be free of any invisible residues. The paint should be applied at room temperature or at a slightly elevated temperature for best results. Multiple coats may be applied, but each successive coat should be kept thin in order to avoid softening of the dried layers beneath. The paint is potentially flammable and poses a mild inhalation hazard, and therefore it should be handled in a well ventilated working place and with care to the hazard potential. Application equipment may be cleaned with most general-purpose commercial paint thinner.

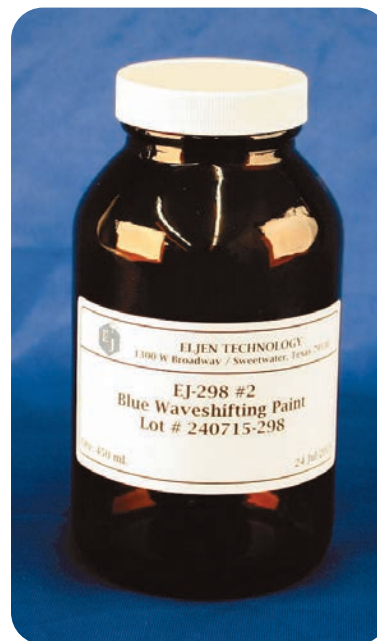

PROPERTIES	EJ-298	EJ-298G
Wavelength of Maximum Emission (nm)	435	490
Wavelength of Maximum Absorption (nm)	375	425
Decay Time (ns)	2	8
Quantum Efficiency (%)	> 0.90	> 0.85

PACKAGE SIZES
450 mL
850 mL
2.5 L
5 L

Chemical Compatibility:

Attacked By: Aromatic solvents, Chlorinated solvents, Ketones, Solvent bonding cements, etc.

Stable In: Water, Dilute acids and alkalis, Lower alcohols, Silicone greases.

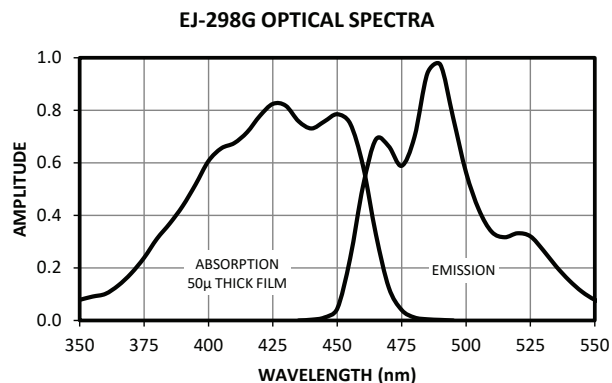
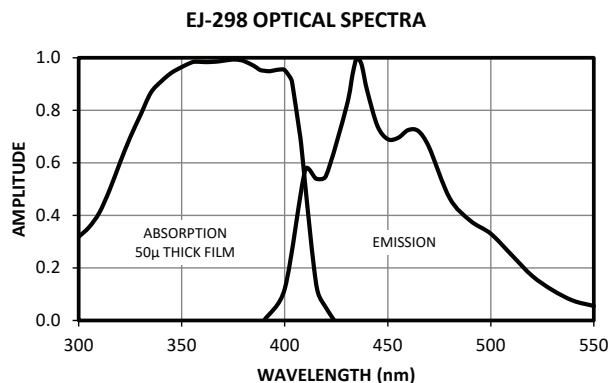

SCINTILLATION AND WAVELENGTH SHIFTING PLASTIC FIBERS

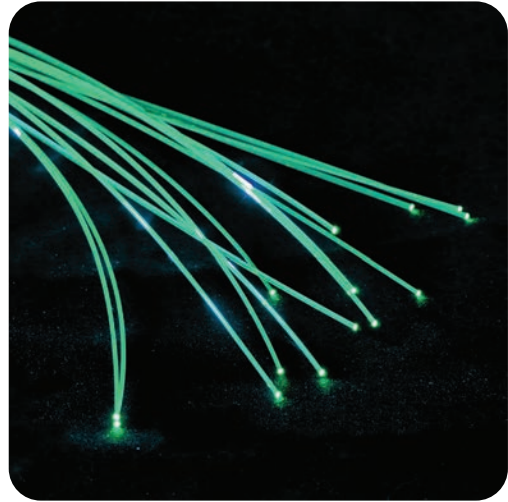
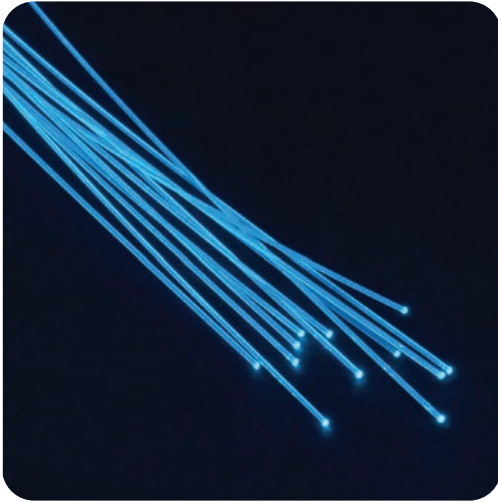

Eljen Technology is proud to introduce our own brand of plastic fiber optics that are designed for applications needing fiber optics and flexibility. In ongoing collaboration with our clients and our extensive experience in the production of plastics, we are embarking on bringing the best in plastic fiber optics to our customers. These new plastic fibers are based on many years of manufacturing the highest quality Organic Scintillators and Wavelength Shifting Plastics for commercial, scientific and government communities.

Eljen's plastic fibers are available in single and double clad, round or square, canes, spools, and bundles, with diameters ranging from 0.3 mm to 5.0 mm. Our cutting-edge fiber draw

systems can also create unclad for filament 3D printing of wavelength shifting and scintillating detector systems.

The fibers can be supplied in plastic matrix bases of polyvinyl toluene (PVT) or polystyrene (PS) and are available in a number of formulations based on our standard Scintillation and Wavelength Shifting plastics. All fibers are drawn and cut to customer specified dimensions and tested to meet specifications.

Please contact us regarding your specific needs and requirements.

COMMON PROPERTIES	FIBER SPECIFICATIONS	
Core Material	PS	PVT
Core Material Light Output (% Anthracene)	58	64
Working Temperature (°C)	100	75
Density (g/cm³)	1.05	1.03
Core Refractive Index	1.59	
Cladding Material	PMMA	
Cladding Refractive Index	1.49	
Cladding Thickness	3% of fiber diameter	
H Atoms per cm³ (core) (x10²²)	5.16	
C Atoms per cm³ (core) (x10²²)	4.68	
Electrons per cm³ (core) (x10²³)	3.33	
Operating Temperature	-60 °C to 60 °C	
Vacuum Compatible	Yes	

FIBER TYPES & SPECIFICATIONS

SCINTILLATING FIBERS

MATERIAL	EMISSION COLOR	EMISSION PEAK (nm)	DECAY TIME (ns)	ATTENUATION LENGTH (m)	PHOTONS PER MeV
EJ-100	Blue	425	2.1	2+	10,000
EJ-104	Blue	408	1.8	2+	10,400
EJ-108	Blue	435	3.3	2+	9,200
EJ-160	Green	490	9.2	2+	9,200
EJ-162	Green	481	2.1	2+	8,700

WAVELENGTH SHIFTING FIBERS

MATERIAL	EMISSION COLOR	ABSORBANCE PEAK (nm)	EMISSION PEAK (nm)	DECAY TIME (ns)	ATTENUATION LENGTH (m)
EJ-180	Green	427	490	8.5	2+
EJ-182	Blue/Green	390	481	1.9	2+
EJ-184	Red	574	608	13	2+
EJ-186	Blue	355	425	~ 1.2	2+

Light Attenuation

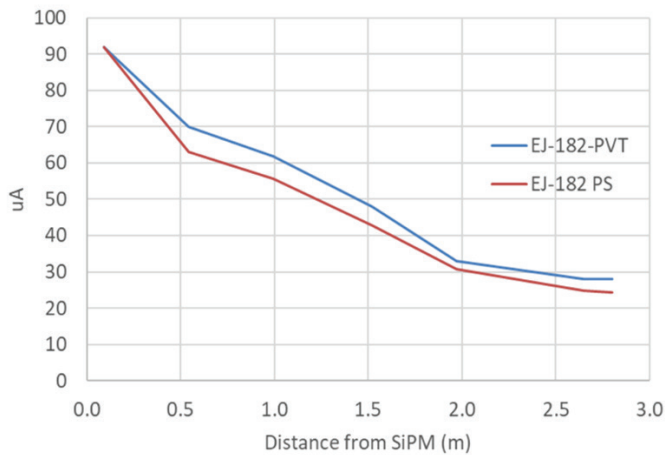

Loss of Signal (1mm Fiber)

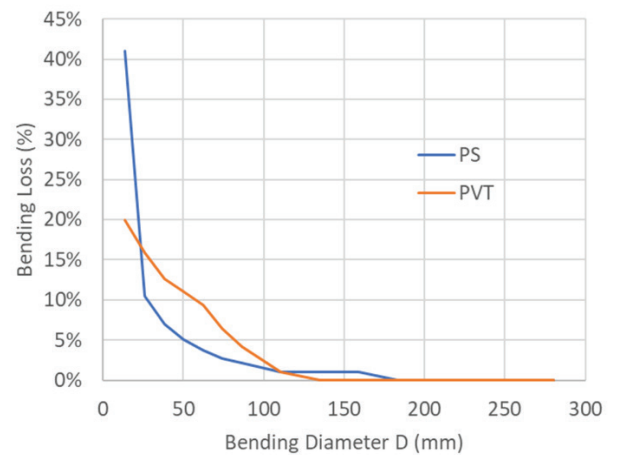

LIGHT GUIDES AND ACRYLIC PLASTIC

Light guides are always custom made for each customer's needs. One general rule to remember when considering using light guides: they usually improve the uniformity of light collection but often reduce the average signal amplitude. Light guide types fabricated by Eljen include, but are not limited to, the following general types:

- **Adiabatic:**
Consists of an array of strips adapting the edges of scintillator plates to a single photomultiplier tube. These generally apply best on wide scintillators and are the most expensive.
- **Fishtail:**
Consists of a single solid element providing a smooth adaption of a rectangular cross section to a round PMT face.
- **Flat Trapezoid:**
Consists of a flat triangular PMMA sheet terminated at the PMT end by a cylindrical rod or disc for effective PMT mounting.

Eljen light guides are fabricated from cast acrylic materials. Cast acrylic is a clear and colorless plastic which generally has good optical clarity and good mechanical properties. It has very little natural scintillation response to ionizing radiation.

Cast acrylic is also known as PMMA (polymethylmethacrylate) and is often referred to in a generic sense by the many commercial product names under which it is manufactured. Some of these names include: Lucite®, Plexiglas®, Perspex®, and Rohaglas®. It is normally made as cast sheet stock with UV absorbing additives for general purpose commercial applications. When the UV absorbers are omitted to obtain optical transmission into the ultraviolet regions, the product is often referred to as UVT. Sheet stock up to about 6 mm (0.25") thick are also made by extrusion processes. However, the best optical properties are obtained with the cast material. Acrylic sheets are also occasionally used in fabricating tanks for selected liquid scintillators. In this case, the cast materials provide superior resistance to chemical attack.



PROPERTIES	PMMA
Specific Gravity at 20°C	1.190
Refractive Index, n_D (589 nm)	1.492
Refractive Index (436 nm)	1.502
H Atoms per cm^3 ($\times 10^{22}$)	5.73
C Atoms per cm^3 ($\times 10^{22}$)	3.58
O Atoms per cm^3 ($\times 10^{22}$)	1.43

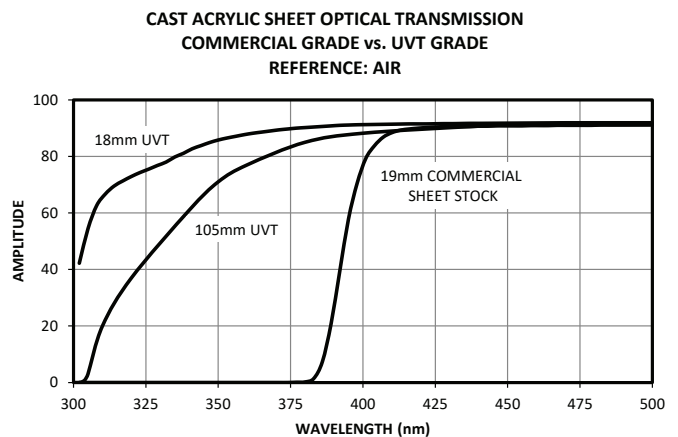
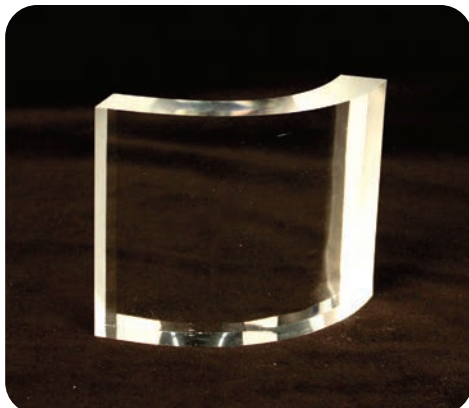

LIQUID SCINTILLATORS

The versatility of liquid scintillation detectors provides an excellent means of approaching many problems in the detection of nuclear radiation. For many years, Eljen Technology has provided the greatest variety of liquid scintillators available from any commercial source. The range includes standard liquid scintillators for pulse shape discrimination applications, for internal sample counting or external detection of radiation, and loaded liquids for neutron and gamma detection.

Liquid scintillators can be supplied ready for immediate use encapsulated at the factory in sealed aluminum or glass cells in a variety of types made to the customer's required dimensions. Liquid scintillators in liter quantities are also supplied in bottles or drums sealed under inert gas.

All liquid scintillators should be stored in clean, dry sealed containers under an atmosphere of inert gas. Materials suitable for construction of containers in contact with liquid scintillators are glass, tin-plated steel, chrome steel, stainless steel, aluminum, indium and Teflon®. The stability of each liquid in the presence of other materials should be determined before a large amount of liquid is committed. After being transferred to a cell or tank the scintillator should be deoxygenated by sparging with pure nitrogen or argon for a duration of time proportional to the cell size immediately before sealing in order to achieve excellent PSD performance.

Complete detector assemblies are also available which incorporate an aluminum cell and a PMT in a light-tight metal housing.



NEUTRON/GAMMA PSD

EJ-301, EJ-309

EJ-301 exhibits excellent pulse shape discrimination (PSD) properties, particularly for fast neutron counting and spectrometry in the presence of gamma radiation. It is identical to the widely reported NE-213 and exhibits all of the properties of that scintillator.

EJ-309 has been developed as an alternate to the more commonly used low-flash point PSD liquid scintillators based on the solvent xylene. With a flash point of 144°C, it eliminates the fire hazard associated with low-flash point liquid scintillators. While EJ-309 provides slightly poorer PSD characteristics than that of EJ-301, EJ-309 possesses a number of chemical properties recommending it for use in environmentally difficult conditions. These properties include: high flash point, low vapor pressure, low chemical toxicity, and compatibility with cast acrylic plastics. EJ-309 is also available loaded with natural boron as EJ-309B.

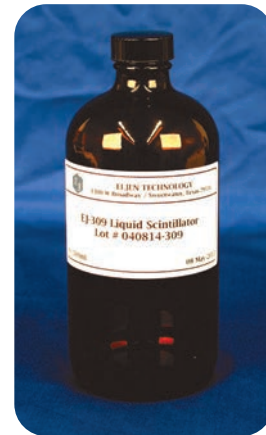
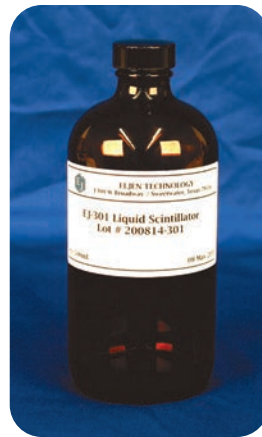

PROPERTIES	EJ-301	EJ-309
Light Output (% Anthracene)	78	80
Scintillation Efficiency (photons/1 MeV e ⁻)	12,000	12,300
Wavelength of Maximum Emission (nm)	425	424
Decay Time, Short Component (ns)	3.2	~ 3.5
Mean Decay Times of First 3 Components (ns)	3.16 32.3 270	-
Bulk Light Attenuation Length (m)	2.5 - 3	> 1
Specific Gravity	0.874	0.959
Refractive Index	1.505	1.57
Flash Point (°C)	26	144
Boiling Point (°C at 1 atm)	141	290 - 300
Vapor Pressure (mm Hg, at 20°C)	6	0.002
H Atoms per cm ³ (×10 ²²)	4.82	5.43
C Atoms per cm ³ (×10 ²²)	3.98	4.35
Electrons per cm ³ (×10 ²³)	2.27	3.16

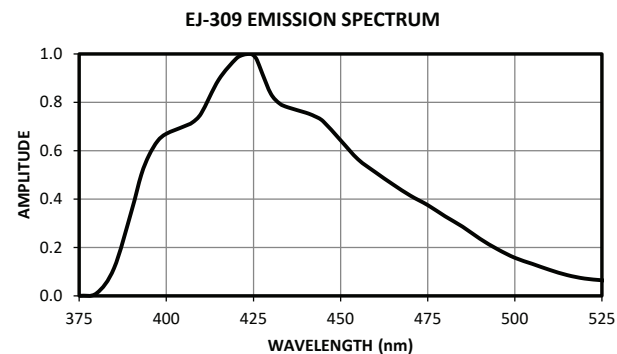
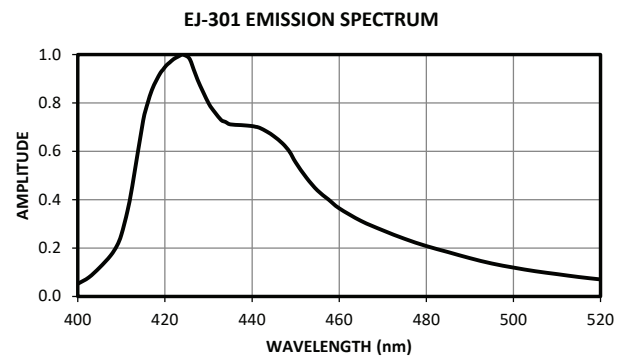

BORON LOADED EJ-309B

EJ-309B is a variant of EJ-309 loaded with natural boron. Loadings up to 5% by weight of natural boron are available. EJ-309B has most of the same general properties as EJ-309. The atomic compositions of three different loading levels are given below.

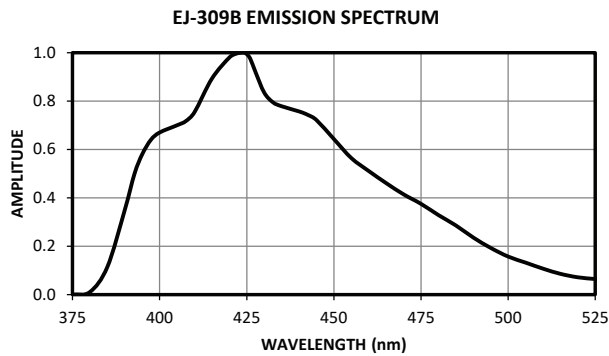

PROPERTIES	EJ-309B (% boron)		
	-5%	-2.5%	-1%
Natural Boron Content (% w/w)	5	2.5	1
Light Output (% Anthracene)	57	64	69
Scintillation Efficiency (photons/1 MeV e-)	8,800	9,800	10,600
Wavelength of Maximum Emission (nm)	424	424	424
Decay Time, Short Component (ns)	~ 3.5	~ 3.5	~ 3.5
Bulk Light Attenuation Length (m)	> 1	> 1	> 1
Specific Gravity	0.963	0.964	0.965
Refractive Index	1.57	1.57	1.57
Flash Point (°C)	144	144	144
Boiling Point (°C at 1 atm)	290 - 300	290 - 300	290 - 300
Vapor Pressure (mm Hg, at 20°C)	0.002	0.002	0.002
H Atoms per cm ³ (×10 ²²)	5.40	5.43	5.44
C Atoms per cm ³ (×10 ²²)	4.13	4.25	4.33
¹⁰ B Atoms per cm ³ (×10 ²⁰)	5.34	2.68	1.07
Electrons per cm ³ (×10 ²³)	3.16	3.17	3.17
¹⁰ B/H Ratio of Linear Attenuation Coefficient for Thermal Neutron Capture	125	62.4	25.1

HYDROGEN FREE EJ-313

EJ-313 is based on highly purified hexafluorobenzene and, as it is almost free from hydrogen, it is relatively insensitive to fast neutrons. Thus, it is useful for gamma ray detection in a fast neutron flux.¹ According to Jupiter and Perez², the ratio of the relative gamma ray response to neutron responses for EJ-313 compared to a xylene-based liquid scintillator is 14.5 for 2.6 MeV neutrons and 8.5 for 1 MeV neutrons. Ewen and Gonsior³ found that the gamma ray and neutron efficiencies of this hydrogen-free scintillator to be 25% and 0.4% respectively, relative to those of a NaI(Tl) detector.

References

1. S. Homma & S. Takemoto, Rev. Sci. Instr. 32, No. 9, 1055 (Sept. 1961)
2. C.P. Jupiter & J. Perez, IEEE Trans. Nucl. Sci., NS-13, (1) 692-703 (1966)
3. K. Ewen & B. Gonsior, Nucl. Instr. & Meth., 99, 573-578 (1972)



PROPERTIES	EJ-313
Light Output (% Anthracene)	20
Scintillation Efficiency (photons/1 MeV e-)	3,060
Wavelength of Maximum Emission (nm)	425
Decay Time, Short Component (ns)	~ 3
Bulk Light Attenuation Length (m)	> 1
Specific Gravity	1.619
Refractive Index	1.38
Flash Point (°C)	10
Boiling Point (°C at 1 atm)	80
F Atoms per cm ³ (×10 ²²)	3.14
H Atoms per cm ³ (×10 ²⁰)	1.02
C Atoms per cm ³ (×10 ²²)	3.15
Electrons per cm ³ (×10 ²³)	4.72

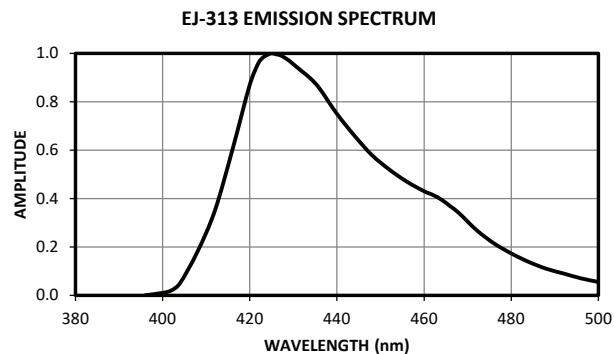

DEUTERATED EJ-315

EJ-315 is based on highly purified deuterated benzene and is useful for fast neutron research. A particularly highly enriched deuterated benzene is employed to achieve the very high D:H ratio of 141:1. A non-deuterated version, EJ-315H, is also available for comparison studies. EJ-315H is based on normal standard benzene, but the formulae of the two scintillators are otherwise identical. The properties of each are presented below.

Because of the toxic nature of benzene, it is strongly recommended that the liquids be ordered in the encapsulated form so you need only to mount your photomultiplier tubes in order to put the scintillator into service.



PROPERTIES	EJ-315	EJ-315H
Light Output (% Anthracene)	60	60
Scintillation Efficiency (photons/1 MeV e ⁻)	9,200	9,200
Wavelength of Maximum Emission (nm)	425	425
Decay Time, Short Component (ns)	3.5	3.5
Bulk Light Attenuation Length (m)	> 3	> 3
Specific Gravity	0.954	0.878
Refractive Index	1.498	1.501
Flash Point (°C)	-11	-11
Boiling Point (°C at 1 atm)	79	80
D Atoms per cm ³ (×10 ²²)	4.06	-
H Atoms per cm ³ (×10 ²²)	0.0287	4.04
C Atoms per cm ³ (×10 ²²)	4.10	4.06
Electrons per cm ³ (×10 ²³)	2.87	2.84

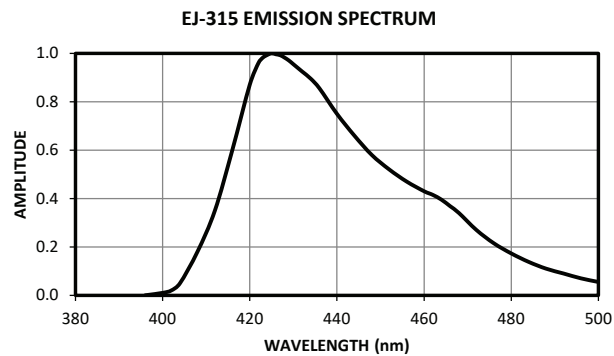

MINERAL OIL BASED EJ-321L, EJ-321H, EJ-321P, EJ-321S

This is a family of four different formulations, **EJ-321L**, **EJ-321H**, **EJ-321P**, and **EJ-321S**, all based on mineral oil. The main difference between these scintillators is the light output, which varies primarily by the percentage of mineral oil in the various solutions. Other properties which vary with the light output are optical mean free path, flash point and hydrogen-to-carbon ratio. They are recommended for use in large tanks, including acrylic tanks, where lower costs are important.

The tendency for chemical action on container components runs in parallel with the light output. In the construction of acrylic tanks, it is strongly recommended that only cell cast sheet stock, not extruded materials, be employed. Glue joints should be made with solvent action cements and should be annealed afterward. Extruded tubing has been successfully used but only when the inside walls of the cells have been passivated with a thin coating of polyvinyl

alcohol. EJ-321P may also be used in tanks fabricated with gray PVC plastic.



PROPERTIES	EJ-321L	EJ-321H	EJ-321P	EJ-321S
Light Output (% Anthracene)				
Saturated with Nitrogen	39	52	28	66
Saturated with Air	30	40	21	51
Mean Free Path (400 - 500 nm, in m)	> 5	> 5	> 6	> 4
Wavelength of Maximum Emission (nm)	425	425	425	425
Decay Time, Short Component (ns)	2.0	2.0	2.2	2.0
Specific Gravity	0.86	0.86	0.85	0.87
Refractive Index	1.47	1.48	1.47	1.49
Flash Point (°C)	102	81	115	74
Minimum Operating Temperature (°C)	-20	-25	—	-24
H Atoms per cm³ (×10 ²²)	7.37	7.03	7.47	6.48
C Atoms per cm³ (×10 ²²)	3.66	3.72	3.63	3.83
Electrons per cm³ (×10 ²³)	2.93	2.94	2.93	2.94

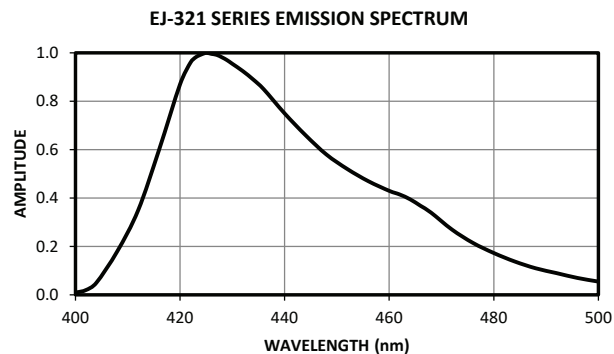

MINERAL OIL BASED WITH PSD

EJ-325A

EJ-325A is a mineral oil based liquid scintillator having pulse shape discrimination (PSD) properties for the separation of fast neutrons and gammas. EJ-325A replaces the original EJ-325. The new formula exhibits slightly improved scintillation efficiency and PSD properties and, importantly, has a very high flash point for safety and ease of shipping. With mineral oil as a major solvent component, EJ-325A possesses greater optical clarity for use in large tanks.

EJ-325A exhibits considerably low solvent properties making it ideal for incorporation in containers fabricated with cast acrylic and PVC.

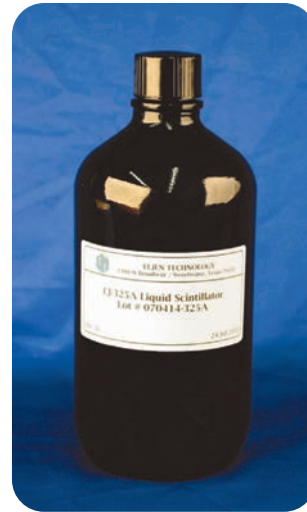

PROPERTIES	EJ-325A
Light Output (% Anthracene)	62
Scintillation Efficiency (photons/1 MeV e ⁻)	9,500
Wavelength of Maximum Emission (nm)	425
Decay Time, Short Component (ns)	~ 3.5
Bulk Light Attenuation Length (m)	> 1
Specific Gravity	0.954
Refractive Index	1.55
Flash Point (°C)	146
Boiling Range (°C at 1 atm)	290 - 300
Vapor Pressure (mm Hg, at 20°C)	0.002
H Atoms per cm ³ (×10 ²²)	6.73
C Atoms per cm ³ (×10 ²²)	3.92
Electrons per cm ³ (×10 ²³)	3.02

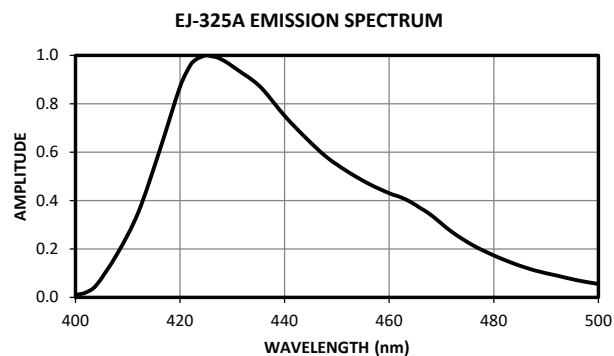

GADOLINIUM LOADED EJ-331, EJ-335

The principal applications of these liquid scintillators are neutron spectrometry and neutrino studies. The neutron capture reaction in gadolinium produces a multiplicity of gamma rays with a total energy of about 8 MeV. Delayed coincidence and pulse shape discrimination techniques are commonly employed with these liquids. Also, because they are often employed in large volumes, both are formulated with high flash point solvents.

EJ-331, based on a fully aromatic solvent, provides the maximum light output consistent with long-term stability. The standard gadolinium loading is 0.5% by weight, but it is also available with gadolinium loadings from 0.1% to 1.5%.

EJ-335 contains mineral oil substituted for some of the aromatic solvent for purposes of higher hydrogen content and higher flash point for use in very large tanks. The maximum gadolinium content is 0.5%, and loadings down to 0.1% are used in very large volume detectors.

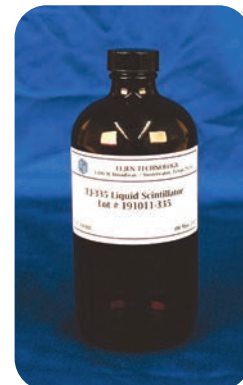
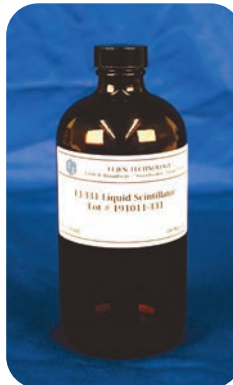

PROPERTIES	EJ-331-0.5%	EJ-335-0.25%
Gadolinium Content (% w/w)	0.5	0.25
Light Output (% Anthracene)	68	55
Wavelength of Maximum Emission (nm)	424	424
Bulk Light Attenuation Length (m)	> 4	> 4.5
Specific Gravity	0.90	0.89
Refractive Index	1.50	1.49
Flash Point (°C)	44	64
H Atoms per cm ³ (×10 ²²)	5.27	6.16
C Atoms per cm ³ (×10 ²²)	4.00	3.93
Electrons per cm ³ (×10 ²³)	2.98	3.06

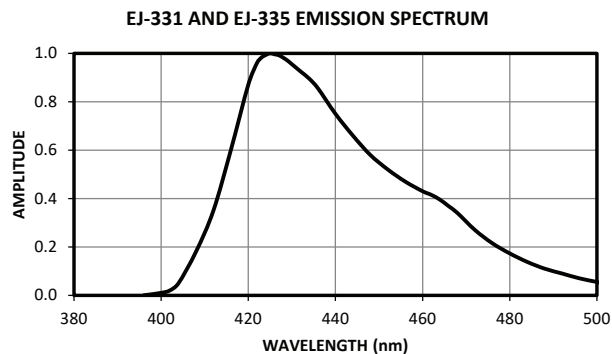

AQUEOUS SAMPLES

EJ-351

EJ-351 is a scintillation cocktail based on highly purified dioxane and is identical to the original NE-220. It is intended primarily for alpha and beta detection in counting water-based solutions of sugars and salts as well as body fluids such as urine and blood serum. It can be used to assay tritiated water. Since it is dioxane-based, it offers very high light output and is relatively resistant to quenching. Water can be added to EJ-351 in quantities up to 10% of the final solution mixture.



PROPERTIES	EJ-351
Light Output (% Anthracene)	65
Scintillation Efficiency (photons/1 MeV e-)	10,000
Wavelength of Maximum Emission (nm)	425
Decay Time, Short Component (ns)	3.8
Specific Gravity	1.036
Refractive Index	1.442
Flash Point (°C)	12
Boiling Point (°C at 1 atm)	104
H Atoms per cm ³ (×10 ²²)	5.32
C Atoms per cm ³ (×10 ²²)	3.23
O Atoms per cm ³ (×10 ²²)	1.14
Electrons per cm ³ (×10 ²³)	2.47

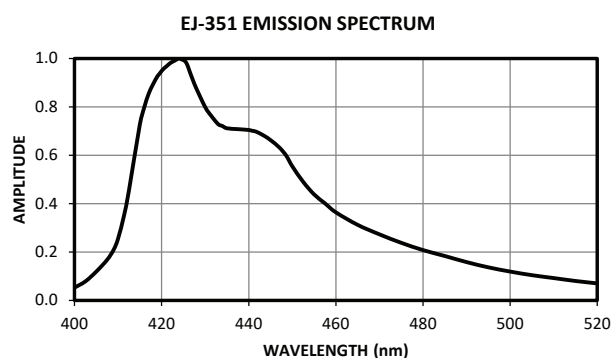

LIQUID SCINTILLATOR CELLS AND DETECTOR ASSEMBLIES

Our liquid scintillators are available encapsulated within either aluminum or glass cells with a clear window for coupling to a photomultiplier tube. The most common model is a cylindrical aluminum cell with one window and a mounting flange. Both cells with an expansion void bubble and bubble-free cells are offered. Standard sizes are 51 mm (2 in) dia., 76 mm (3 in) dia., and 127 mm (5 in) dia. regular cylinders. Custom sizes are also available. Aluminum liquid scintillator cells can also be supplied with a photomultiplier tube as a complete detector assembly. Assemblies include a photomultiplier tube, voltage divider, Mu-shielding and light-tight housing.

Expansion Void Cell With Flange
VMF-D×H Liquid Scintillator Cell

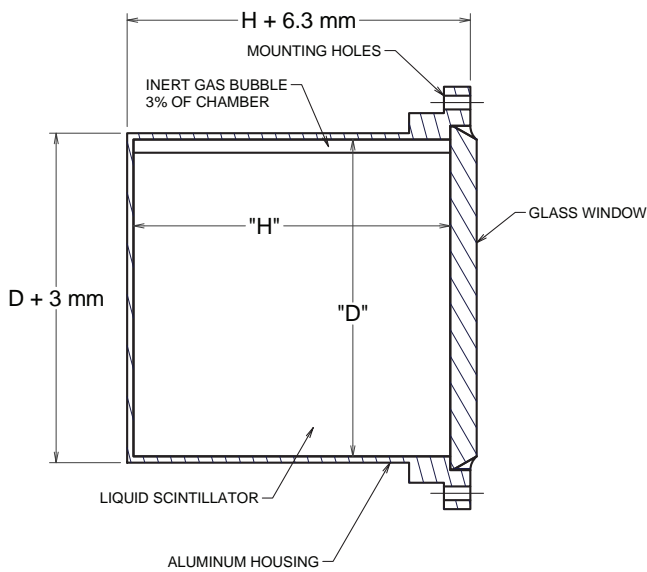

Bubble-Free Cell With Flange
BFF-D×H Liquid Scintillator Cell

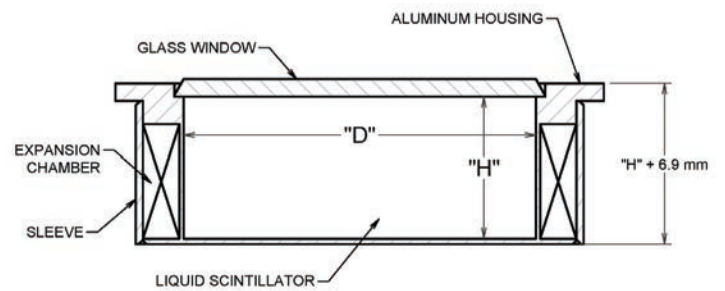

M510-30×30 (3 in Dia.) Liquid Scintillator Detector Assembly

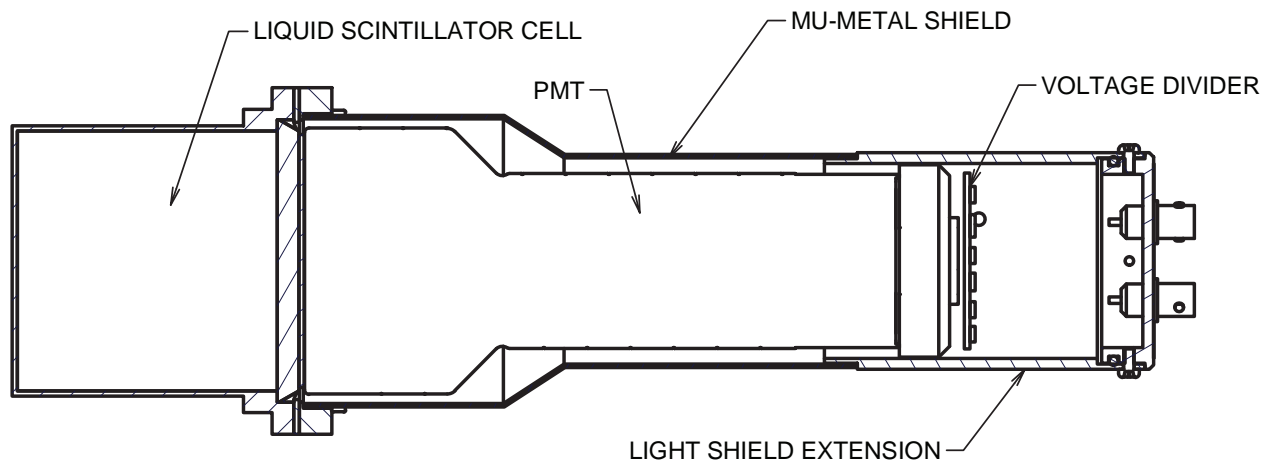

SCINTILLATORS FOR NEUTRON DETECTION

Eljen Technology offers three products specifically for neutron detection which possess an intrinsic low sensitivity for gamma radiation. EJ-410 is a detector for fast neutrons, composed of an acrylic disc embedded with concentric rings of ZnS:Ag scintillator. EJ-420 and EJ-426 are detectors for thermal neutrons and both are composed of a matrix of ZnS:Ag and Li6. EJ-420 is offered as a disc, while EJ-426 is offered as either disc or sheet material with a variety of support backing materials.



FAST NEUTRON DETECTION

EJ-410

EJ-410 is specifically designed for detecting fast neutrons while being nearly insensitive to gamma radiation. The detector consists of zinc sulfide phosphor embedded in a hydrogenous polymer matrix structured in a series of concentric cylinders of clear plastic to facilitate light collection. Recoil protons generated in the detector produce scintillation pulses in the phosphor. Electrons scattered in the detector by gamma radiation interact very weakly with the ZnS:Ag particles, providing scintillation pulses easily eliminated from the counting systems by setting an appropriate threshold.

EJ-410 is an inert plastic disc which can be mounted to a photomultiplier tube either directly or by means of a suitable light guide. Optical greases, silicone rubbers or epoxies may be used with the EJ-410. A variety of blue-sensitive photomultiplier tubes may be used.

GAMMA DISCRIMINATION

Gamma scintillation pulses are usually smaller than those generated by neutrons. In gamma fields below 1 R/hr, pulse height discrimination can easily be used to reject the gamma pulses. However, the randomly generated recoil protons will generate a broad scintillation pulse height spectrum. Therefore, in high gamma fields, the simultaneous detection of multiple gammas can generate pulse heights large enough to be in the normal neutron spectrum. The consequent higher discriminator settings needed will then reduce the neutron detection efficiency. Additional gamma rejection may be achieved by using time constants of a few microseconds.

PROPERTIES	EJ-410
Wavelength of Maximum Emission (nm)	450
Decay Time, Short Component (μ s)	0.2
Maximum Operating Temperature ($^{\circ}$ C)	90

STANDARD SIZES	
Thickness (mm)	15.9
Diameter (mm)	25, 38, 50, 76, 127

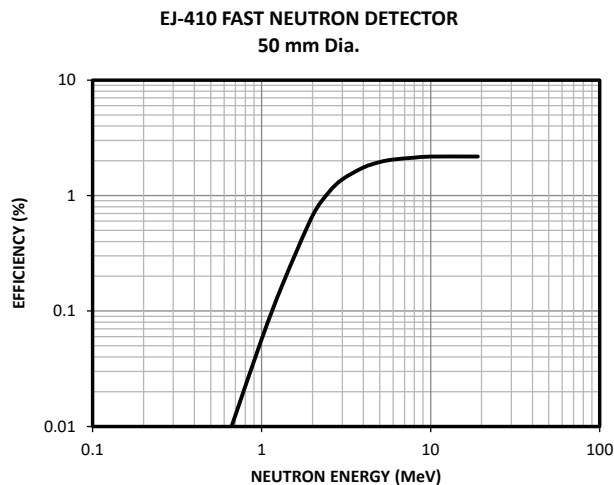

THERMAL NEUTRON DETECTION

EJ-420

The **EJ-420** detector is an efficient detector of thermal neutrons in the presence of gamma radiation. The detector employs a lithium compound, whose Li content is enriched to 95% ${}^6\text{Li}$ dispersed in a ZnS:(Ag) matrix. Efficient measurements of thermal neutron fluxes may be performed in the presence of gamma radiation as high as 10^7 gamma rays per neutron.

In most applications, EJ-420 will give counting efficiencies up to 100% greater than those attainable with similar detectors based on ${}^{10}\text{B}$. The efficiency is dependent on the neutron energy and is approximately 30% for 0.1 eV neutrons and 60% for neutrons of energy 0.01 eV or less. The detection efficiency for thermal neutrons of about 0.025 eV is approximately 55%. The attainable detection efficiency in a particular application will, of course, also depend on the competing gamma ray background.

The detection process in EJ-420 depends on the nuclear reaction ${}^6\text{Li} (n, \alpha) {}^3\text{H}$:

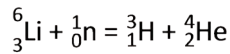

with a cross section of 941 barns for 0.025 eV neutrons. The resulting triton and alpha particle are efficiently detected in a ZnS:(Ag) phosphor especially selected for short decay time characteristics.

For typical applications EJ-420 is optically bonded to a photomultiplier tube with clear silicone grease or fluid. It may be surrounded by an appropriate quantity of hydrogenous material for neutron thermalization. The neutron flux is

determined above a desired rejection ratio of gamma radiation or photomultiplier noise by setting the pulse height analyzer or discriminator of the associated electrical equipment to an appropriate level. This is adequate for most applications, but if the flux of gamma rays is very high, pulse shape discrimination may be effectively used.

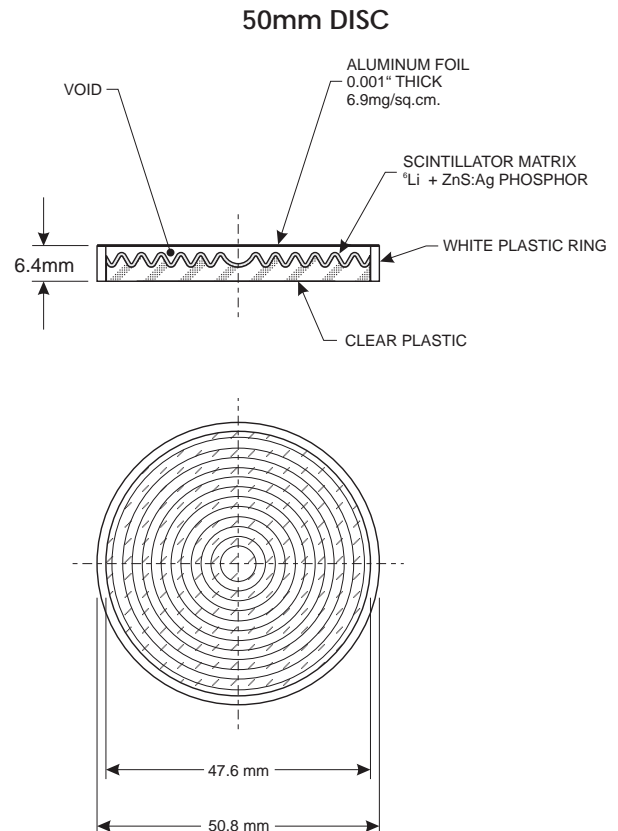

PROPERTIES	EJ-420
${}^6\text{Li}$ Content (mg/cm ²)	9
Pulse Height (% NaI(Tl))	120
Wavelength of Maximum Emission (nm)	450
Decay Time, Short Component (μs)	0.2

STANDARD SIZES	
Thickness (mm)	6.5
Diameter (mm)	25, 38, 50, 76, 127

THERMAL NEUTRON DETECTION

EJ-426

EJ-426 is an efficient detector for thermal neutrons with low sensitivity to gamma radiation. The detector has the form of a flat, white, thin sheet consisting of a homogeneous matrix of fine particles of lithium-6fluoride (${}^6\text{LiF}$) and zinc sulfide phosphor (ZnS:Ag) compactly dispersed in a colorless binder. The lithium is enriched in ${}^6\text{Li}$ to a minimum of 95 atom percent.

The neutron detection process employs the nuclear reaction ${}^6\text{Li} (n, \alpha) {}^3\text{H}$:

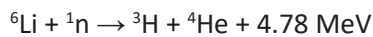

with a cross section of 941 barns for 0.025 eV neutrons. The resulting triton and alpha particle are detected by ZnS:Ag phosphor with the broad blue fluorescent spectrum shown below. The decay time of the prompt scintillation component is 200 ns.

EJ-426 sheets can be manufactured in a large variety of sizes and formulas and are usually supplied with a support backing. Most types are heat formable. The tables below present the product variations currently available.

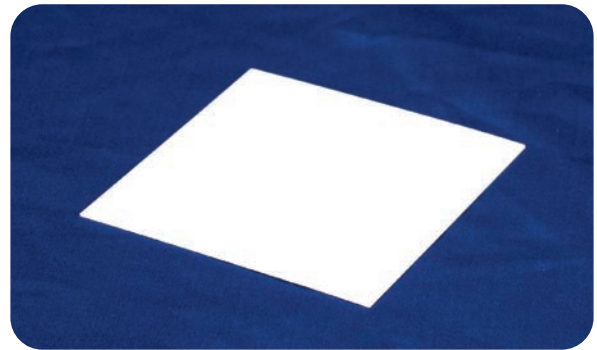

DETECTION PROPERTIES			
Screen Type		EJ-426-0	EJ-426HD
${}^6\text{LiF}:\text{ZnS}$ Mass Ratio		1:3	1:2
${}^6\text{Li}$ Density (atoms/cm ³)		8.81×10^{21}	1.07×10^{22}
Theoretical N TH Efficiency	0.32 mm thick	0.21	0.25
	0.50 mm thick	0.31	0.36

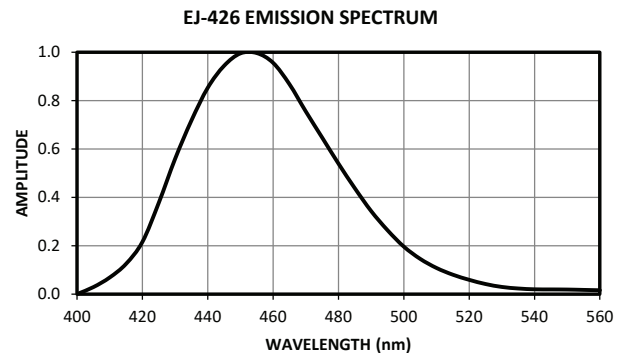

FORMULA		
EJ-426-0		
EJ-426HD		
MATRIX THICKNESS		
0.32 mm		
0.50 mm		
BACKING		
MATERIAL TYPE	DESCRIPTION	SUFFIX
Aluminum Foil	50 μm thick foil	(none)
Clear Polyester Sheet	0.25 mm thick sheet	-PE
	Laminated between two 0.25 mm thick sheets	-PE2
Aluminized Mylar	0.12 mm thick sheet	-AM
Pure Aluminum	0.5mm thick plate	-PA
High Reflective Aluminum	0.4mm thick plate	-A

STANDARD PRODUCT SPECIFICATIONS

When requesting EJ-426, please specify the desired formula, matrix thickness, backing material, and sheet size. Standard options are listed in the table on the left. Custom formulations and variations are also available. The maximum sheet size is 400mm x 500mm.

EXAMPLE

Product Number: EJ-426-0-PE

Description: Phosphor matrix with 1:3 ${}^6\text{LiF}$ to ZnS mass ratio on 0.25 mm thick clear polyester sheet.

Sheet Size: 0.32 mm thick \times 100 mm \times 100 mm

ZINC SULFIDE COATED SHEETS AND DISCS

Eljen Technology offers three different zinc sulfide (ZnS:Ag) coated products for alpha or alpha/beta detection. EJ-440 and EJ-442 are products designed specifically for alpha detection. EJ-440 consists of a polyester sheet coated with ZnS:Ag while EJ-442 consists of a non-flexible support material coated with ZnS:Ag. EJ-444 is designed for alpha/beta detection and discrimination and consists of a thin sheet of EJ-212 plastic scintillator coated with ZnS:Ag.

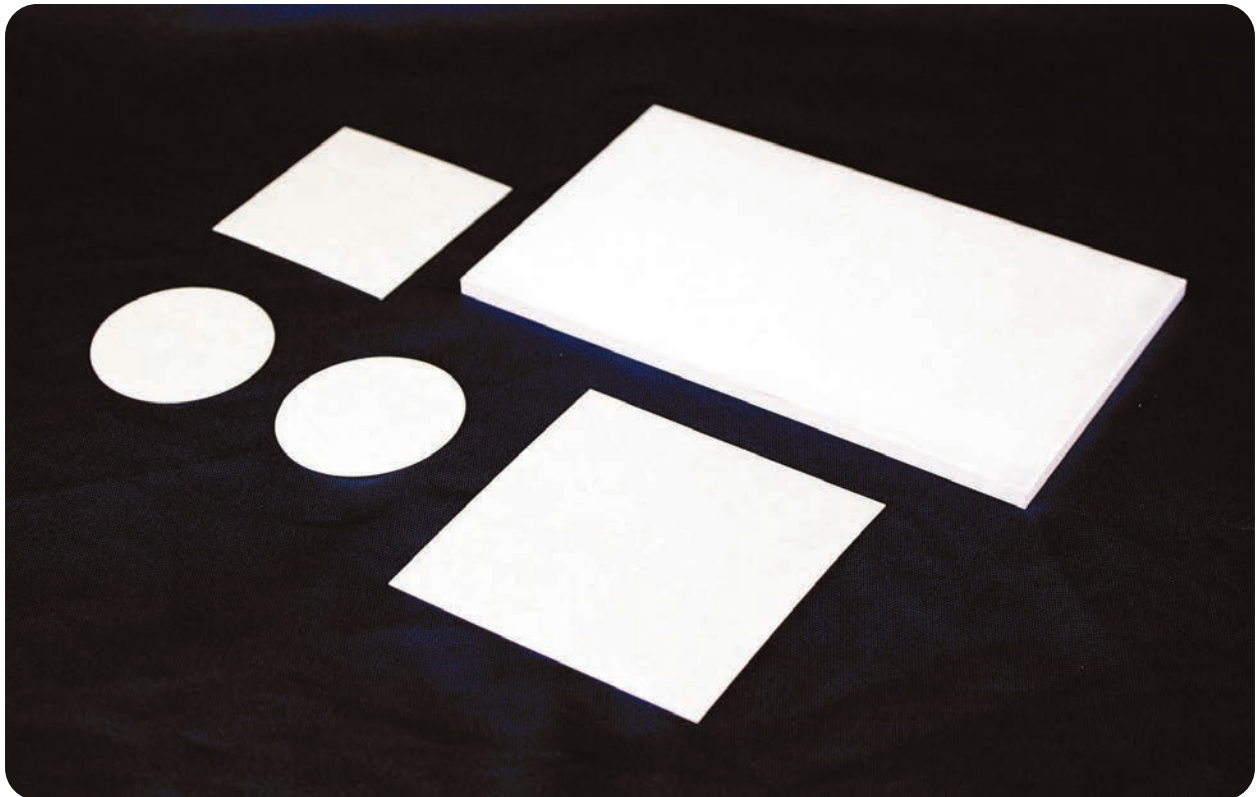

ALPHA DETECTION

EJ-440, EJ-442

These products consist of a very uniform deposit of blue-emitting P22 type silver activated zinc sulfide phosphor (ZnS:Ag) applied to one side of a backing material. They are specifically intended for alpha particle detection, and the phosphor layer density is sufficient to completely absorb common alpha particles such as those from ²⁴¹Am. Batch to batch uniformity of alpha sensitivity is constant within a $\pm 1.5\%$ range. The phosphor layer is smooth and sufficiently robust to withstand normal handling.

EJ-440 consists of ZnS:Ag phosphor applied to a clear polyester plastic sheet. The sheets are quite flexible and can easily be cut with scissors or a paper cutter.

EJ-442 consists of ZnS:Ag phosphor applied to one side of a thick, non-flexible support material. This product is custom-made to satisfy each customer's specific requirements. The most common support materials are acrylic plates, but metal support plates have also been used. These materials are very stable, and their shelf life at room temperature is at least two years.

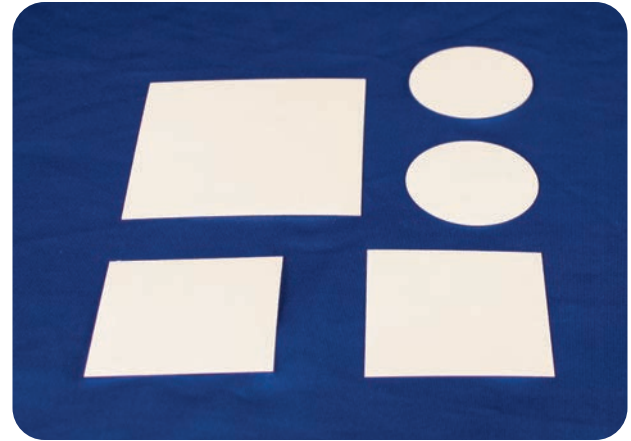

PROPERTIES	EJ-440 EJ-442
Light Output (% Anthracene)	300
Wavelength of Maximum Emission (nm)	450
Decay Time (ns)	200
Phosphor Density (mg/cm ²)	3.25 \pm 0.25
EJ-440, Thickness of Polyester Film (mm)	0.25
EJ-440, Density of Polyester Film (mg/cm ²)	36

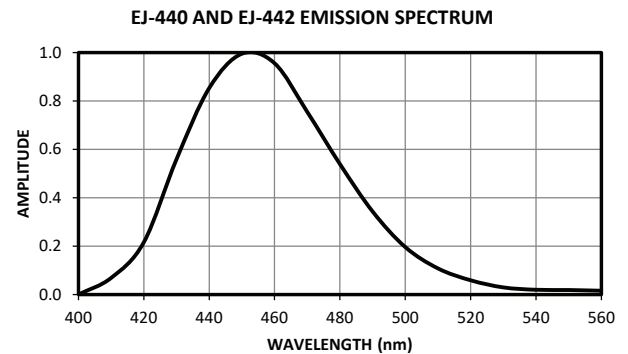

Chemical Compatibility:

The adhesive is soluble in common alcohols and other organic solvents. It is insoluble in water.

EJ-440 STANDARD SIZES	
Sheets	216 mm \times 279 mm (8.5" \times 11")
	305 mm \times 305 mm (12" \times 12")
Discs	25 - 50 mm diameter
Custom sizes are also available.	

EJ-442 STANDARD SIZES	
Acrylic Plate Thickness	1.5 - 5 mm
Maximum Size	300 mm \times 300 mm
Custom sizes are also available.	

ALPHA/BETA DETECTION

EJ-444

EJ-444 consists of a thin piece of EJ-212 plastic scintillator with a layer of silver activated zinc sulfide phosphor (ZnS:Ag) applied to one side. The primary use of EJ-444 is the detection of alpha and beta particles in health physics instrumentation. A non-coated plastic scintillator may also be used for this purpose, but the amplitudes of the alpha and beta pulses are sufficiently similar to make it difficult to separate the two by simple counting electronics making use of counting windows. In contrast, the ZnS:Ag layer on the EJ-444 is made just thick enough to stop all common alpha particles while allowing many low energy betas to pass into the plastic scintillator layer for detection. C-14 betas may be detected with moderate efficiency.

The plastic scintillator component is usually kept quite thin in order to minimize gamma sensitivity. This allows even energetic betas such as from P-32 and SrY-90 generate pulses

grouped in a fairly narrow amplitude region that is below the amplitudes of over 95% of the alpha pulses generated in the ZnS:Ag layer. The standard thickness in EJ-444 is 0.25 mm, but it is also available in greater thicknesses of which 0.5 mm and 1 mm are typical. Thicknesses less than 0.25 mm are also available. The EJ-444 alpha detection efficiency is essentially the same as achieved with bare plastic scintillator.

To give an indication of the beta detection efficiencies of EJ-444, counting comparisons were made between bare 0.25 mm thick EJ-212 and EJ-444 made with an identical EJ-212 component. The bare plastic scintillator is considered to be a reliable reference for maximum detection of the radioactive particles investigated. The results are highly uniform from batch to batch, and the typical values are presented below.

PROPERTIES	EJ-212	ZnS:Ag
Light Output (% Anthracene)	65	300
Wavelength of Maximum Emission (nm)	423	450
Decay Time (ns)	2.4	200
Density (g/cm ³)	1.023	-
Phosphor Density (mg/cm ²)	-	3.25 ± 0.25

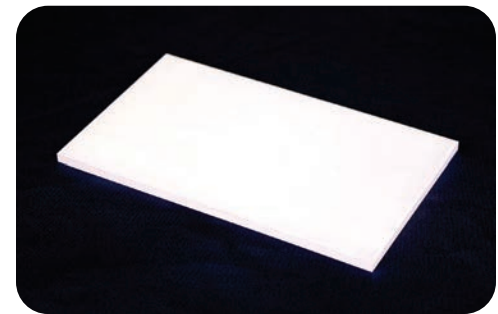

RADIATION TYPE	RELATIVE EFFICIENCY EJ-444 count ÷ EJ-212 count
C-14 Beta (E _{max} = 156 keV)	66%
Tc-99 Beta (E _{max} = 294 keV)	80%
SrY-90 Beta (E _{max} = 544 keV, 2.3 MeV)	96%

Note: See page 56 for alpha and beta pulse height spectra.

STANDARD SIZES	
SHEETS	
Thickness	Max. Area
0.25 mm	250 mm × 250 mm
0.5 - 3 mm	300 mm × 300 mm
DISCS	
Thickness	Diameter
0.25 - 3 mm	25 - 50 mm
Custom thicknesses and dimensions are also available.	

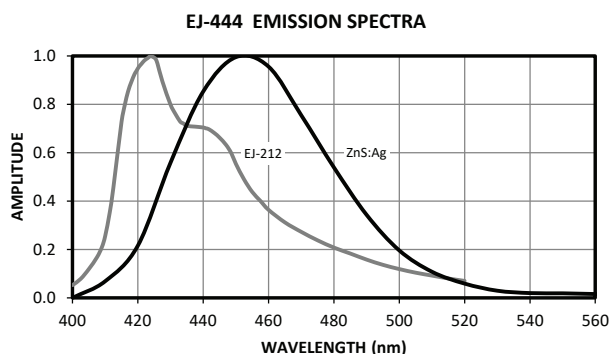

ZnS:Ag PHOSPHOR POWDER

EJ-600

Silver activated zinc-sulfide, ZnS:Ag, is a free-flowing white fluorescent powder with an exceedingly high scintillation efficiency. It is primarily used for alpha particle detection. The most common detector format is a thin flat plate of inert glass or plastic to which the ZnS:Ag is affixed in a thin uniform layer on one side. Such scintillating screens provide very high intrinsic detection efficiency for alpha particles while having very low sensitivity for beta particles and gamma rays.



PROPERTIES	EJ-600
Phosphor Type	Blue
Light Output (% Anthracene)	300
Wavelength of Maximum Emission (nm)	450
Decay Time (ns)	200
Density (g/cm ³)	4.09
Refractive Index	2.356
Melting Point (°C)	1850
Typical Particle Size (μm, nominal)	8

STANDARD QUANTITIES
5 g
10 g
25 g
50 g
100 g
200 g
500 g

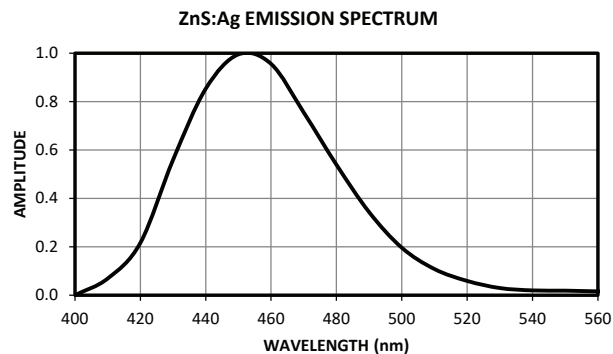

ACCESSORIES AND DETECTOR ASSEMBLY MATERIALS

Eljen Technology offers a variety of materials necessary to make complete detector assemblies using our scintillator products. These products include: optical cement for scintillator connection joints, reflective paint for plastic scintillators, reflective paint for liquid scintillator containers, silicone grease or silicone rubber pads for photomultiplier tube coupling, and various protective wrapping materials.



OPTICAL CEMENT

EJ-500

EJ-500 is a clear and colorless epoxy cement with refractive index at 1.57. It is ideal for optically bonding plastic scintillators and acrylic (PMMA) light guides. It is equally effective with PVT (polyvinyltoluene) or polystyrene based scintillators and may also be confidently used for making butt joints of optical fibers with polystyrene cores. This cement has a degree of flexibility making it useful for optically bonding glasses or the above plastics to glass windows. The optical transmission plot applies to a 0.125 mm (0.005") thick layer in comparison to air. It may also be used to cement metal or ceramic parts to plastic scintillators or PMMA light guides.

EJ-500 is fully cured at room temperature (20°C) with a working life of 60 minutes. The mixed cement takes 3-4 hours to set and 24 hours to harden, although it takes several days to achieve complete cure.



PROPERTIES	EJ-500
Mixed Viscosity (cps)	800
Bond Strength (psi)	1800
Dielectric Strength (volts/mil)	420
Specific Gravity, Cured	1.17
Service Temperature (°C)	-65 to 105
Volume Resistivity, 25°C (ohm-cm)	10 ¹⁴
Coefficient of Thermal Expansion (per °C)	7.2 × 10 ⁻⁵
NASA Outgassing Properties	
Mass Loss (%)	1.69
Condensed Volatiles (%)	0.04

PACKAGE SIZES
300 g
600 g

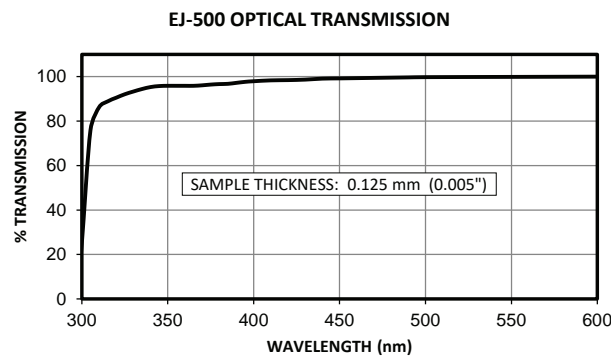

REFLECTIVE PAINT

EJ-510

EJ-510 reflective paint for plastic scintillators is a bright white paint consisting of titanium dioxide pigment and a water soluble paint base selected for excellent resistance to yellowing and good adhesion. While primarily intended for coating of blue-emitting plastic scintillators, EJ-510 employs a blend of pigments selected also for enhanced reflectivity for longer wavelength scintillators with green emissions. This is a diffuse reflector for use on scintillators where the length is not greater than twice the width. It should not be used on long, narrow, optical elements. In addition to plastic scintillators, EJ-510 has been successfully applied to acrylic light guides and a variety of metals.

Maximum reflectivity is achieved by the application of three or four thin coats of EJ-510. After it has thoroughly dried, EJ-510 is not water soluble. However, it may be removed from a painted article by gentle rubbing with the aid of a mixture of water and isopropanol. One liter of EJ-510 can easily cover 10 square meters with three layers of the coating.

Note: EJ-510 should not be used on hygroscopic materials such as some inorganic scintillators.

Instructions For Use: Always shake well before each use. Apply to clean, dry, sanded (240 - 400 grit) or sand-blasted surfaces for best adhesion. Paint may be diluted with water as needed for application. Allow paint to dry thoroughly between coats. For best reflectivity, apply a minimum of three coats.

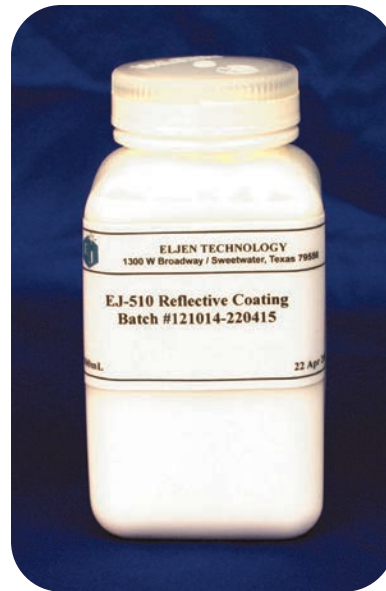

PACKAGE SIZES
500 ml
1000 ml

COMPOSITION	EJ-510
Typical 3-Layer Coating Thickness (mm)	0.11
Typical Density of Dried Coat (mg/cm ²)	13
Ti Atoms per cm ² (×10 ¹⁹)	6.71
C Atoms per cm ² (×10 ²⁰)	1.12
H Atoms per cm ² (×10 ²⁰)	2.25
O Atoms per cm ² (×10 ²⁰)	1.90

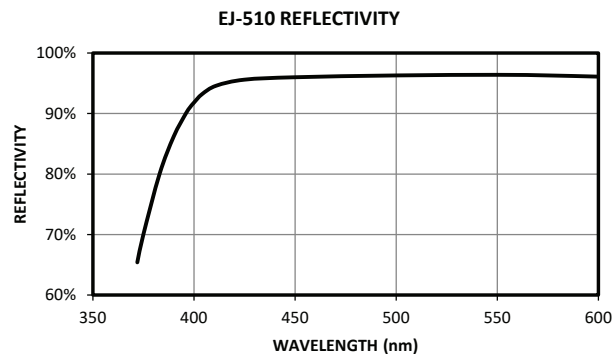

SILICONE GREASE

EJ-550, EJ-552

These two materials are offered for use in optically coupling photosensors to scintillators and light guides. They are packaged in convenient squeeze tubes. Both have low bleed and evaporation rates at 25°C and are safe for handling and storage when exercising standard cleanliness procedures.

EJ-550 Optical Grade Silicone Grease is a clear and colorless optical coupling compound having moderate viscosity and providing excellent transmission properties well into the near-ultraviolet region. It should be stored at temperatures below 26°C, preferably below 5°C. EJ-550 retains clarity and fluid property down to -60°C.

EJ-552 General Purpose Silicone Grease is a translucent grease having high viscosity. It is recommended for use where the very best optical coupling is not required. It is best pressed out to a thickness below 0.1 mm where it becomes nearly transparent. It is best stored at room temperature.



EJ-550

EJ-550 OPTICAL TRANSMISSION
0.1 mm THICK

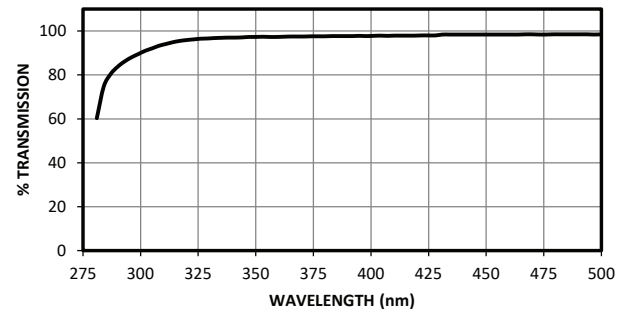

PROPERTIES	EJ-550	EJ-552
Specific Gravity	1.06	1.06
Refractive Index	1.46	1.47
Package Size	30 g, 90 g, 150 g, 450 g (1 lb)	150 g

WRAPPING MATERIALS

EJ-554, EJ-556, EJ-558

EJ-554 is a black vinyl adhesive tape used to make sealed and secure black vinyl wrappings for light-tight plastic scintillator detector assemblies.



EJ-556 and **EJ-558** are protective coverings used to protect plastic scintillator and acrylic light guide surfaces while in transport or during machining. EJ-556 is a paper backed covering and EJ-558 is a low-tack, transparent, poly backed covering.

STANDARD ROLL SIZES	
EJ-554	51 mm wide × 0.25 mm thick × 30.5 m long 102 mm wide × 0.25 mm thick × 30.5 m long
EJ-556	305 mm wide × 91 m long 610 mm wide × 91 m long
EJ-558	305 mm wide × 304.8 m long 610 mm wide × 304.8 m long

SILICONE RUBBER OPTICAL INTERFACE

EJ-560

EJ-560 silicone rubber has been developed specifically for making optical joints between photosensors and plastic scintillators. The rubber material is quite soft and flexible and can be made to conform to contoured surfaces. It is a fully-cured polymer designed so its surfaces are slightly sticky to the touch, and it can be deformed under mild pressure. Nevertheless, it does not flow like a grease and will not extrude irreversibly out of its compression region, making it ideal for long-term coupling of photomultiplier tubes to scintillators.

EJ-560 is available in either pre-cut discs or sheet form. The sheet material can easily be cut to size with razor blades or scissors. All EJ-560 products are shipped with the surfaces masked with an easily removed thin film.

EJ-560 rubber will easily adhere to any smooth surface and can also easily be peeled away without damaging either component. If the EJ-560 surfaces become covered with dust, their adhesive properties will be diminished. However, they can be restored to their original condition by cleaning with the aid of any lower alcohol, such as isopropyl alcohol.



PROPERTIES	EJ-560
Density (g/cm ³)	1.03
Hardness, Shore A	16-24
Refractive Index	1.43
Operating Temperature Range (°C)	-40 to 70
Thermal Expansion Coefficient (cm/cm per °C)	3 × 10 ⁻⁴

STANDARD SIZES	
Thickness	1 mm, 1.5 mm, 2 mm, 3mm
Diameter	28 mm, 38 mm, 51 mm Custom diameters also available from 10 - 125 mm
Sheet Maximum Size	330 mm × 530 mm (1 - 3 mm thick)

EJ-560 OPTICAL TRANSMISSION
2 mm THICK
(REF: AIR)

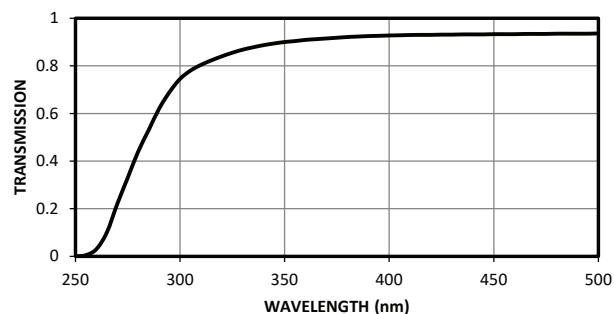

STORAGE AND HANDLING OF PLASTIC SCINTILLATORS

STORAGE: Eljen plastic scintillators are commonly shipped with adhesive paper protecting its surfaces. Keep this paper on as long as possible until the scintillators are actually put into use to minimize abrading and touching of the polished surfaces. Cutting and machining can be done with the paper in place.

Scintillator sheets or plates are best stored standing on their long edge set on a soft material such as foam rubber sheet. When stacked lying flat, place at least 0.25 in (6 mm) of foam rubber between and underneath the pieces. The foam should take up at least 75% of the sheet surface area. Avoid storage conditions which present hard pressure points against the scintillator surfaces.

TEMPERATURE: Standard room temperatures in the range 65 - 80°F (18 - 27°C) are best. Long-term storage above 100°F is not recommended as this will accelerate both oxidative yellowing of the scintillator and the setting of the protective adhesive paper permanently to the plastic.

MOISTURE: While plastic scintillators can be exposed to water without damage, they are permeable to airborne moisture. If the scintillator will experience substantial drops in temperature below normal room temperature, moisture trapped within the scintillator can cause fogging in the plastic. To prevent this, it is recommended to store the scintillator in a dry environment. Eljen uses a dry storage environment to store scintillators likely to be used in applications where low temperatures are expected. Please contact Eljen if your application will expose the scintillator to low temperatures.

LIGHTING: Exposure to sources of UV light can hasten the development of a yellow discoloration from oxidation at the surfaces in much the same way as it does this to any organic material. The most common UV sources are fluorescent lights and sunlight. Unprotected scintillator may be exposed to normal fluorescent lighting for several hours (< 24 hrs.) without danger of degradation.

Extended exposure to direct sunlight should be avoided as the solar UV intensity can be several orders of magnitude higher than that from room lights.

SOLVENTS: Absolutely avoid exposure to most organic solvents and their fumes. Such materials include paint thinners, degreasers, acetone and ketones.

The lower alcohols are generally safe; however, we strongly recommend using only a high purity grade of isopropyl alcohol (isopropanol) for general cleaning of the plastics unless the user has extensive experience with plastic scintillators and knows how to minimize the cooling effects of the more rapidly evaporating alcohols, especially methanol.

Plastic scintillators may be cleaned with water solutions of quality detergents such "Alconox" and dishwashing detergents which do not contain lemon oils. These should be well rinsed when done.

HANDLING: During handling and assembly of counters, clean cotton or plastic gloves should be worn to minimize scratching and fingerprints. Bonding should be accomplished by using an optical-grade epoxy, such as Eljen EJ-500 Optical Cement. Do not use solvent bonding materials often used with acrylic plastics. If a reflective foil is to be used as a wrapping for the counter, use only food grade aluminum foil.

HIGH TEMPERATURE OPERATION: If you plan to use Eljen plastic scintillators for extended periods (months) at temperatures above 95°F (35°C), please contact Eljen Technology for advice in optimizing their performance in your application.

SUMMARY: While Eljen plastic scintillators are far more resistant to crazing than plastic scintillators from the past, their functioning longevity can be optimized by observing a few easy guidelines.

- Do not store the plastic where solvent vapors might be expected.
- Leave the protective adhesive paper on a clean scintillator until use.
- Avoid sharp pressure points.
- Bare-handed handling of scintillators should be avoided by using gloves.
- Clean by using only tepid water or pure isopropyl alcohol.
- Avoid rapid changes in temperature.
- Avoid direct exposure to sunlight.
- Maximum temperature should be just below 60°C (140°F). Normal operating and storage temperatures should be well below this.

STORAGE AND HANDLING OF LIQUID SCINTILLATORS

Eljen liquid scintillators are formulated with particular care regarding purity and long-term service for a wide variety of research applications. They are all based on organic liquids which vary greatly to satisfy the wide range of uses intended for them, and therefore they exhibit greatly varying levels of solvent activity for many of the commonly encountered storage and handling materials such as rubbers and plastics. All of our liquids can be relied upon to exhibit a long performance life and storage stability, typically lasting for many years. However, this depends on their not being contaminated by improper handling.

The following are general guidelines for handling any of Eljen's liquid scintillators. There will be some exceptions for special formulations, such as those intended for use in very cold or hot environments, or for unusual liquids, such as fluorinated ones.

TEMPERATURE: Liquid scintillators should be stored near room temperature, typically $20 \pm 5^{\circ}\text{C}$ ($70 \pm 10^{\circ}\text{F}$). Short-term excursions of an additional 5°C (10°F) will do no harm.

STORAGE ENVIRONMENT: Liquid scintillators should be stored under dry conditions, generally inside a building where direct sun or rain is avoided.

INERT GASES: All organic materials slowly oxidize in the presence of oxygen to develop yellow discoloration. This is accelerated by UV light and heat. The presence of oxygen (air) in the liquid also reduces the scintillation efficiency by 15 - 20% and quenches pulse shape discrimination (PSD) properties.

Humid air can slowly introduce trace amounts of moisture to the liquid until saturation, generally at a very low water concentration, is achieved. Once saturation is achieved, a small drop in temperature can make the moisture condense into tiny droplets in the liquid to form a fog.

All Eljen liquids are factory sealed under an inert gas, and the liquid is saturated with an inert gas, usually nitrogen. We strongly recommend that customers store Eljen liquid scintillators under similar conditions, whether in a detection chamber or in a storage container. This is normally achieved by simply passing a fine stream of dry nitrogen bubbles through the liquid and venting the container so the gas space above the liquid can be filled with the nitrogen at the end of the process. Argon gas may also be employed here.

Short-term exposure to air while handling the liquids will not harm them.

STORAGE CONTAINERS: It is best to keep the liquid in the original containers if practical. If not practical, see list below for safe container materials. Large tanks should be made of stainless steel (304 alloy is adequate). Care should be taken to assure that moist or humid air cannot enter such tanks where night cooling may condense the moisture to form a liquid layer at the bottom of the tank.

GASKETS, HOSES AND CONTAINER MATERIALS

Safe materials:

- Stainless steel
- Aluminum
- Glass
- High quality tinned metal
- Teflon[®], plain and glass-filled
- Viton rubber
- Some epoxies

Unsafe materials:

- Extruded acrylic plastic
- Most plastics
- Most rubber materials
- Most commercial paints
- Bare steel

Safe for some liquids under certain conditions:

- Cast acrylic sheet
- PVC plastic sheet and pipe
- Nylon plastic sheet or rod
- Clear vinyl tubing (Tygon[®])

SUMMARY

- Always exercise caution regarding possible chemical toxicity, fumes and fire hazard. Read the Safety Data Sheet (SDS) provided.
- Maintain good cleanliness of all containers and handling equipment.
- Avoid greases and lubricants.
- When transferring, pumping and pouring, use grounded equipment and practices to avoid static build-up.

MACHINING AND POLISHING OF PLASTIC SCINTILLATORS

SAFETY: Always exercise safety precautions appropriate to the machines to be used. Always wear adequate eye and body protection.

HEAT AND MECHANICAL STRESS: Avoid procedures that would introduce significant stress in the materials such as overheating during the machining and polishing or tight clamping with metal jaws on the plastic. The protective adhesive paper should be left on during room-temperature fabricating and finishing of edges. Use diluted soapy water and cotton or very soft flannel cloth to clean finished surfaces. Avoid exposure to all kinds of solvents except water or alcohol; isopropyl alcohol (isopropanol) is preferred.

SAWING: Band sawing is preferred among the many varieties available. Saw blades must be sharp, and four-pitch buttress type band saw blades are recommended. Since overheating at the cut is unavoidable, allow for the machining removal of at least 0.25 in (6 mm) of scintillator from the cut for sheets up to 0.5 in (13 mm) thick. Larger margins may be required for thicker material. Use spray water or wax stick lubricant where possible, particularly on thicknesses above 1 in (25 mm). The following table may serve as a beginning guide. Sawing on table saws or panel saws with carbide-tipped blades may also be done.

Thickness	Blade Speed (per min.)	Saw Teeth Per Inch
< 1/8 in (3mm)	1800 ft (500 m)	14
1/8 - 1 in (3 - 25 mm)	1800 ft (500 m)	4
> 1 in (25 mm)	1000 ft (300 m)	4

MACHINING COOLANTS: Do not use metal cutting oils. Fine soapy water sprays are recommended. Where metal corrosion may be a problem, some diluted water-soluble oils may be used, but avoid prolonged exposure of the scintillator to them. Do not soak the masking paper on the sheet stock. When drilling, use only water or soapy water coolants.

CLAMPING: Avoid sharp pressure points. For turning and milling, clamp lightly using suitable wood or plastic blocks to spread out the pressure. Avoid trapping dirt between the scintillator and other surfaces.

MACHINE TURNING: Standard metal cutting lathes can be used. Refer to the following tables as a starting guide.

Diameter	RPM
< 2 in (50 mm)	1000
2 - 5 in (50 - 125 mm)	500 - 1000
> 5 in (125 mm)	200 - 500

Prevent vibrations and use feed rates in the range of 0.0015 - 0.004 in (0.04 - 0.2 mm) per revolution. Use sharp, smooth ground, high speed, steel tools with large clearances and slight negative rakes. The following parameters are recommended:

End Cutting Angle	20°
Side Cutting Angle	10°
Back Rake Angle	-2°
End Clearance Angle	12°
Side Clearance Angle	10°
Nose Radius	Up to 0.18 in (4 mm)
Tool Location	Up to 2° above centerline

MILLING: Use fly cutters where possible with cutter speeds and feed rates similar to those recommended for turning. When using end mills, use a two wing sharp helix cutter with a compressed air blower to keep chips free.

DRILLING: For shallow or small diameter holes (below 1/8 in (3 mm)) the drill should have a point angle of 60° – 90° instead of the standard 118°. It should have wide flutes and a low helix angle with lip clearance at the periphery of 12°. Take great care to avoid overheating by using soapy water coolant. Do not clean the hole with a low alcohol as the evaporation cooling may start crack formation. Recommended drilling speeds are as follows:

Diameter	RPM
1/16 - 5/16 in (1.5 - 8 mm)	500 - 700
3/8 - 1/2 in (10 - 13 mm)	300

(Continued on page 50)

(Continued from page 49)

SANDING: Remove turning lines by hand, rubbing at right angles using #240 grit silicon carbide waterproof paper with water. Follow with #400 and #600, also with water. Each step should be at right angles to the previous one until all previous lines are removed.

HAND POLISHING: Use polishing aluminas on small areas and holes. Finishing with a particle size of 9 microns. Form a paste with water on a flannel cloth. Rinse away the alumina and use a general purpose non-abrasive plastic polishing liquid available from most plastic supply companies for final cleaning. Use a clean, soft flannel cloth in this final step. Generally avoid using polishing liquids on drilled holes or heat-bent pieces.

MACHINE POLISHING: Avoid lingering on any one spot and keep buffer speeds and pressures down in order to minimize surface heating. A suitable buffer wheel surface speed is 1400 - 1800 (400 - 500 m) per minute corresponding

to about 750 RPM for an 8 in (200 mm) diameter buffing wheel. Avoid rounding of the sheet edges by clamping a small strip of plastic on each side.

1. **First Operation:** Use a 1" wide unstitched ventilated-type buffing wheel with a brown #150 grade relatively dry compound bar.
2. **Second Operation:** Use a separate but similar buffing wheel as above with a dry aluminum oxide compound bar.
3. **Final Operation:** Polish with a clean, soft, unstitched flannel wheel using no compound.

CLEANING: Clean water and soapy water are the best solvents to use. These are the only fluids to be used when cleaning bored and drilled holes and on scintillators having extensive machining and polishing. Wipe or pat dry with clean, soft, non-abrasive cloths or tissues. The lower alcohols may also be used. Isopropyl alcohol is preferred because of its slower evaporation rate. Avoid industrial grades of alcohols which may contain harmful impurities.

STRUCTURAL PROPERTIES OF EJ-200 PLASTIC SCINTILLATOR

(Characteristics of Eljen PVT Based Scintillator Material)

PROPERTY	UNITS	TEST PROCEDURE	THICKNESS	
			50 mm	150 mm
Yield Strength	MPa	ASTM D638	30.8	28.3
Breaking Strength	MPa	ASTM D638	30.8	28.3
Tensile Modulus	MPa	ASTM D638	2700	3010
Flexural Strength	MPa	ASTM D790	45.6	40.5
Flexural Modulus	MPa	ASTM D790	2920	2700
Compressive Strength	MPa	ASTM D695	38.1	40.5
Compressive Modulus	MPa	ASTM D695	1380	2700
Shore "D" Hardness	-	ASTM D2240	84	84

1 MPa (megapascal) = 145 psi = 10^6 N/m²

PLASTIC SCINTILLATOR RESPONSE CURVES

RESPONSE OF PLASTIC SCINTILLATORS
TO ATOMIC PARTICLES

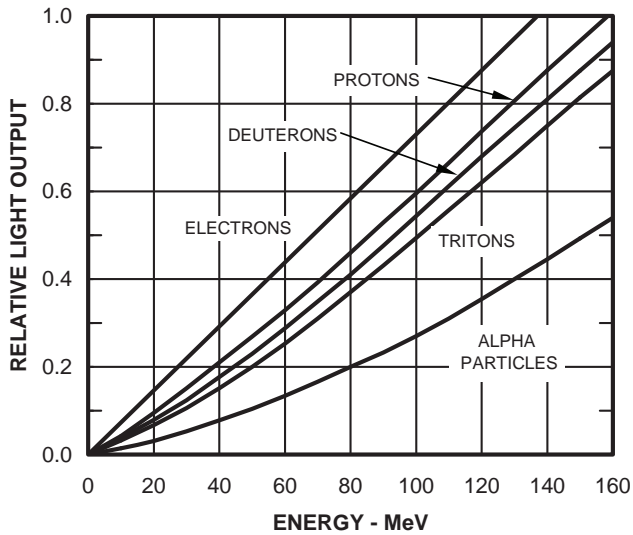

RANGE OF ATOMIC PARTICLES
IN PLASTIC SCINTILLATOR

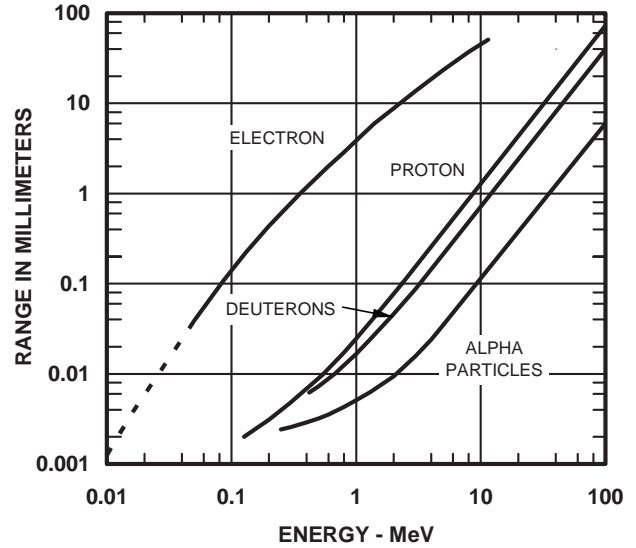

LIGHT COLLECTION IN PLASTIC SCINTILLATOR
(END OPPOSITE PMT BLACKENED)

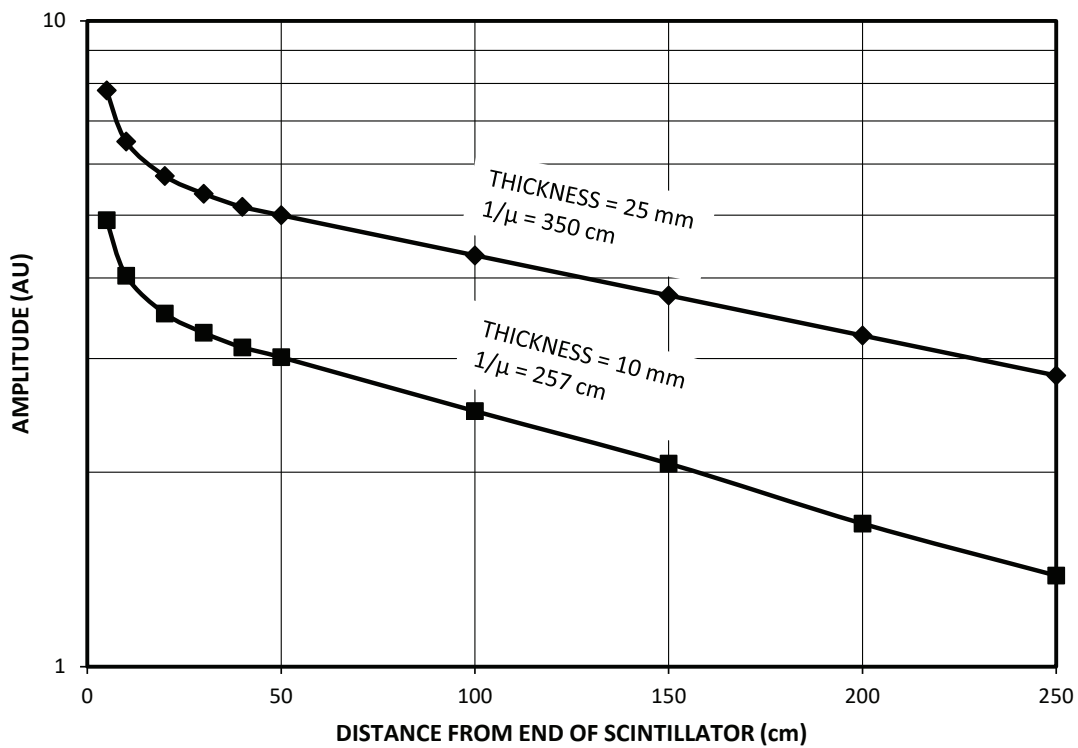

RESPONSE OF EJ-200 SCINTILLATION LIGHT PRODUCED VS. PARTICLE ENERGY

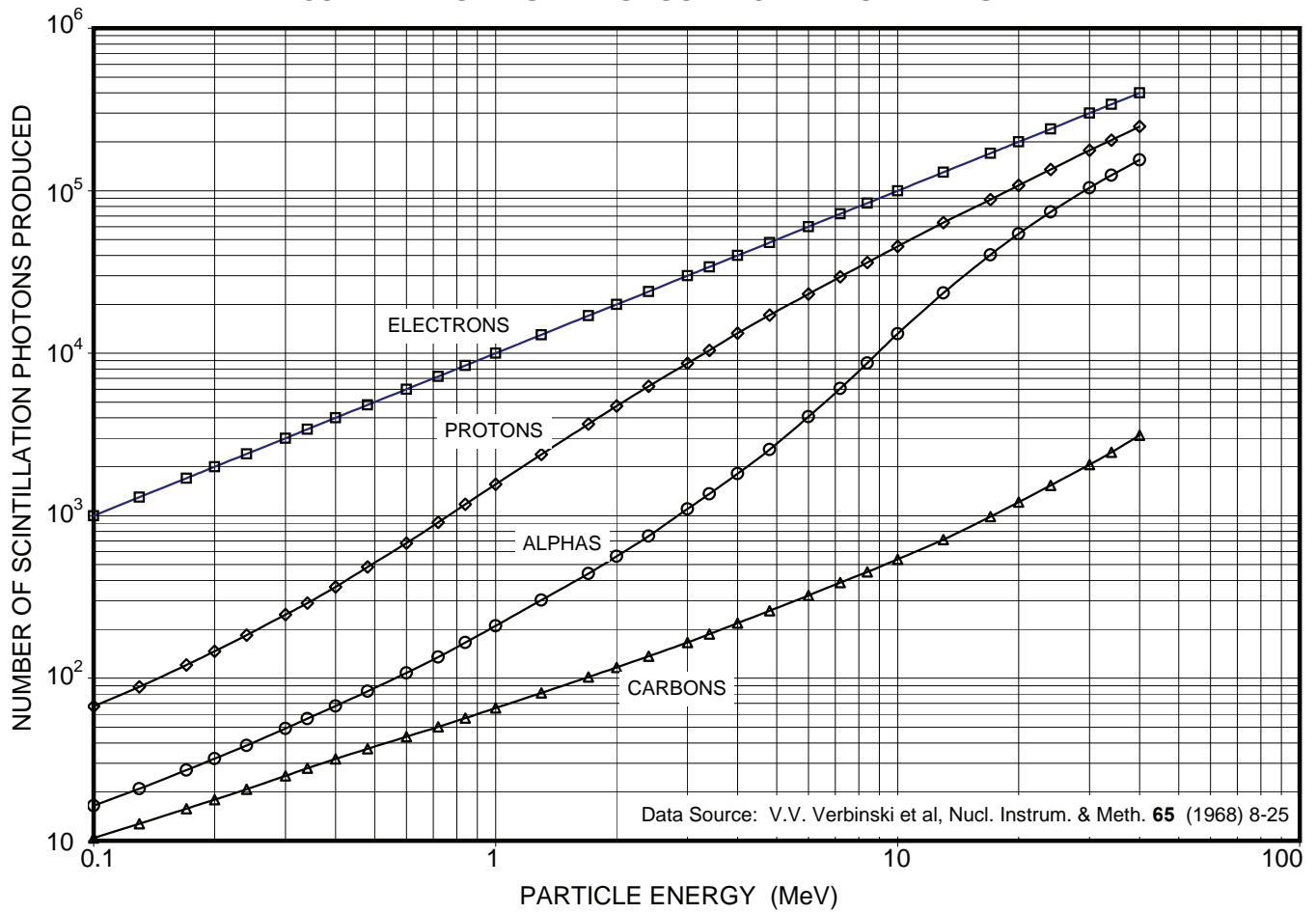

EJ-200 GAMMA ATTENUATION COEFFICIENTS

Linear Attenuation Coefficients, $\mu\text{-lin}$ (cm^{-1})

Specific Gravity: 1.023

keV	Photoelectric	Compton	Pair Production	Total Less Coherent
1	2063.28	0.0161	0	2063.29
1.5	653.08	0.0319	0	653.12
2	281.68	0.0489	0	281.73
3	83.7022	0.0796	0	83.782
4	34.7676	0.1030	0	34.870
5	17.4191	0.1197	0	17.538
6	9.8443	0.1315	0	9.9764
7	6.0430	0.1396	0	6.1973
8	3.9597	0.1471	0	4.1068
9	2.7156	0.1523	0	2.8771
10	1.9379	0.1572	0	2.0952
15	0.5215	0.1725	0	0.6939
20	0.2032	0.1803	0	0.3835
25	0.0973	0.1829	0	0.2943
30	0.0533	0.1851	0	0.2383
40	0.0205	0.1840	0	0.2045
50	0.0097	0.1810	0	0.1908
60	0.0053	0.1773	0	0.1826
70	0.0032	0.1732	0	0.1767
80	0.0020	0.1696	0	0.1717
90	0.0014	0.1657	0	0.1672
100	9.63×10^{-4}	0.1623	0	0.1633
150	2.53×10^{-4}	0.1468	0	0.1471
200	9.93×10^{-5}	0.1348	0	0.1349
300	2.78×10^{-5}	0.1174	0	0.1174
400	1.19×10^{-5}	0.1053	0	0.1053
500	6.38×10^{-6}	0.0962	0	0.0962
511	6.03×10^{-6}	0.0953	0	0.0953
600	3.97×10^{-6}	0.0889	0	0.0890
660	3.16×10^{-6}	0.0852	0	0.0852
700	2.75×10^{-6}	0.830	0	0.0830
800	2.00×10^{-6}	0.0781	0	0.0781
900	1.56×10^{-6}	0.0739	0	0.0739
1000	1.24×10^{-6}	0.0703	0	0.0703
1022	1.15×10^{-6}	0.0696	0	0.0696
1250	7.79×10^{-7}	0.0628	0	0.0629
1500	5.66×10^{-7}	0.0571	7.69×10^{-5}	0.0572

**Co-60 & Cs-137 DETECTED BY A
2 in DIA. × 2 in EJ-200 SCINTILLATOR**

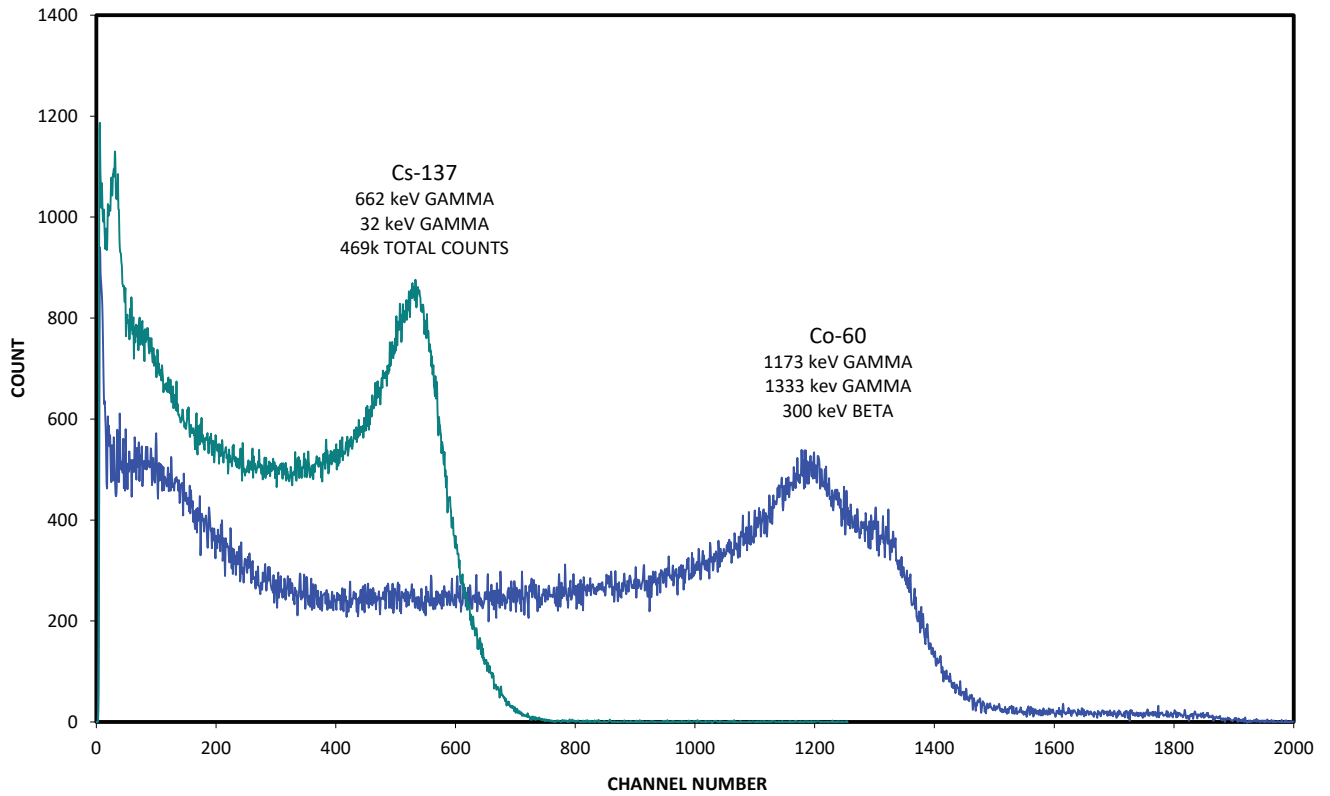

**BETA/GAMMA EFFICIENCY VS. THICKNESS
IN EJ-212 PLASTIC SCINTILLATOR**

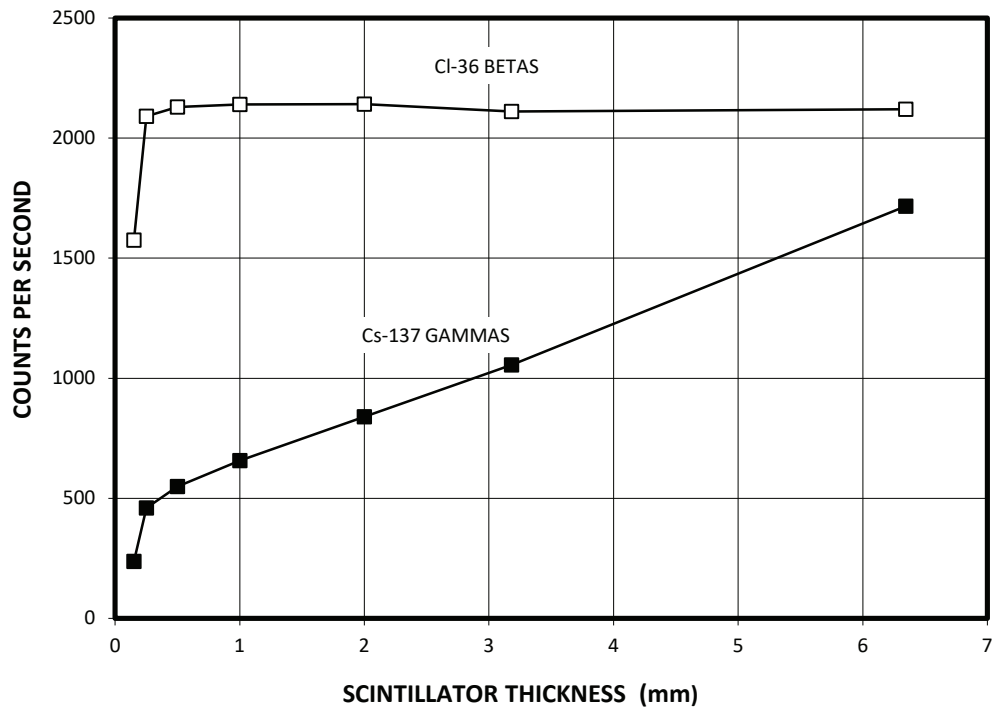

EJ-444 (0.25 mm THICK)
ALPHA AND BETA PULSE HEIGHT SPECTRA
GRAPH A - FULL ALPHA SPECTRUM

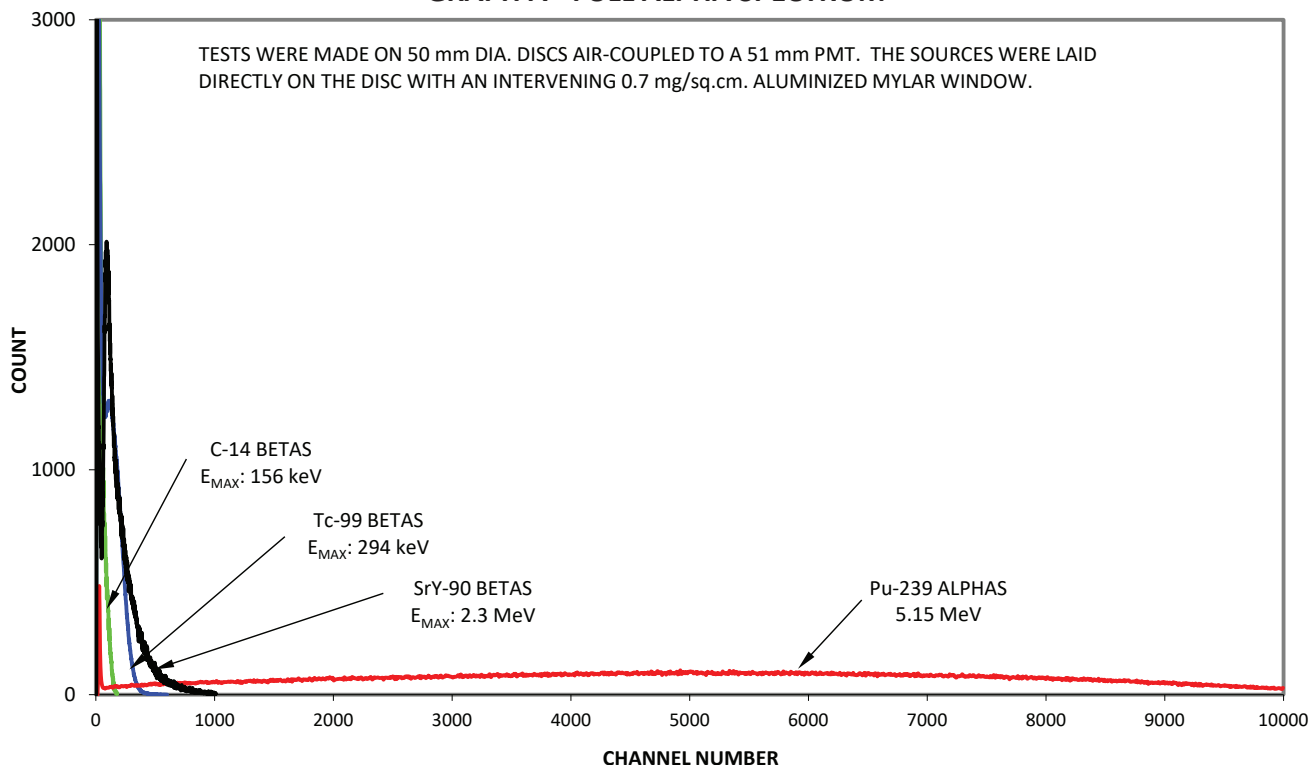

EJ-444 (0.25 mm THICK)
ALPHA AND BETA PULSE HEIGHT SPECTRA
GRAPH B - AMPLIFIED LOW ENERGY REGION

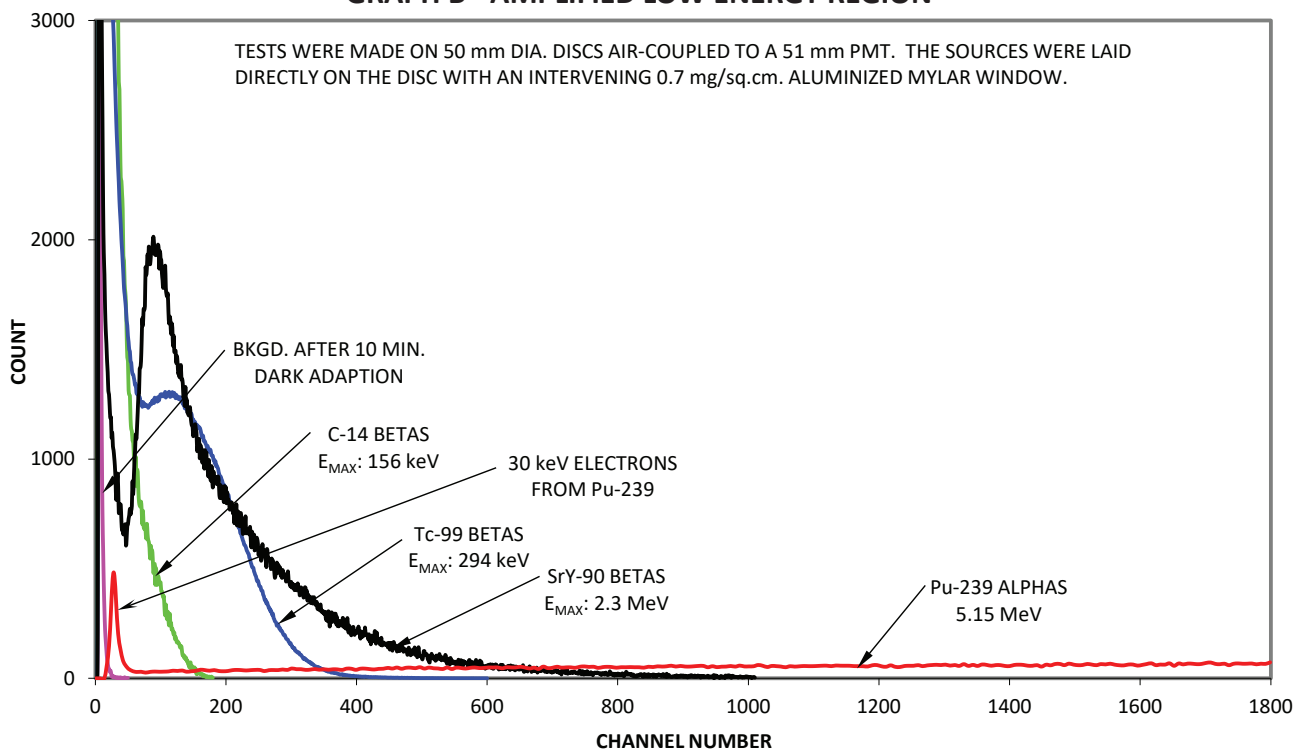

GAMMA DETECTION EFFICIENCY NOMOGRAM

This nomogram and the accompanying curves make possible a rapid determination of the detection efficiency of an organic phosphor.

For detection, a certain minimum energy must be transferred to a Compton electron. The cross section can be calculated by integrating the differential Compton cross section from the corresponding minimum photon scattering angle to 180 degrees.

One starts with the minimum acceptable energy transfer (discriminator-bias setting). From Fig. 1 one then finds the cross section for detectable energy transfer, σ . To determine the corresponding absorption coefficient μ , ($= \rho\sigma$) we use the three scales on the left of the nomogram. The nomogram then determines the efficiency ($1 - e^{-\mu\chi}$) from μ and the thickness χ .

The method assumes equality of total linear absorption coefficient and detection absorption coefficient. This is generally justified by crystal geometries in which a photon that is scattered by an event *not* leading to detection cannot escape from the crystal without traversing the remainder of the path lengths.

With 25-keV bias we observe efficiencies that correspond to our curve above 200 keV. Below 200 keV the cross section is larger than calculated, apparently due to multiple collisions.

Example: Discriminator bias is at 25 keV, and we are detecting 200 keV photons in a 10 cm thick plastic phosphor. From the curves we find a detection cross section of 0.27 barns. A representative phosphor has $\rho = 3.4 \times 10^{23}$ electrons/cm³. With this assumption we find a detection efficiency of 60%.

(Note: All standard Eljen plastic scintillators have electron densities of approximately 3.4×10^{23} electrons/cm³.)

(Originally printed in *Nucleonics Data Sheets* as "Gamma-Detection Efficiency of Organic Phosphors" by K. I. Roulston and S. I. Naqvi)

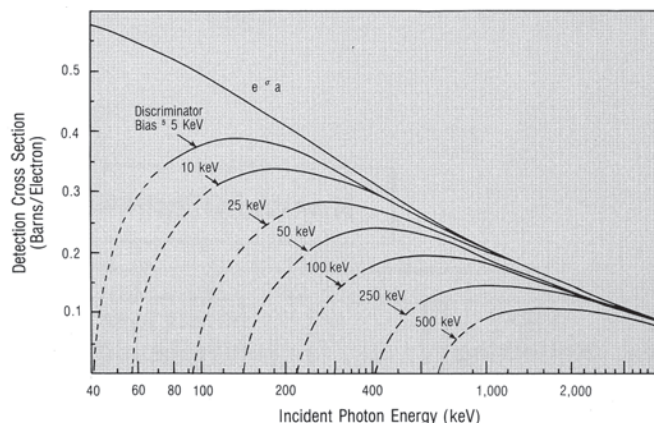

Fig. 1. Detection cross section vs. incident photon energy

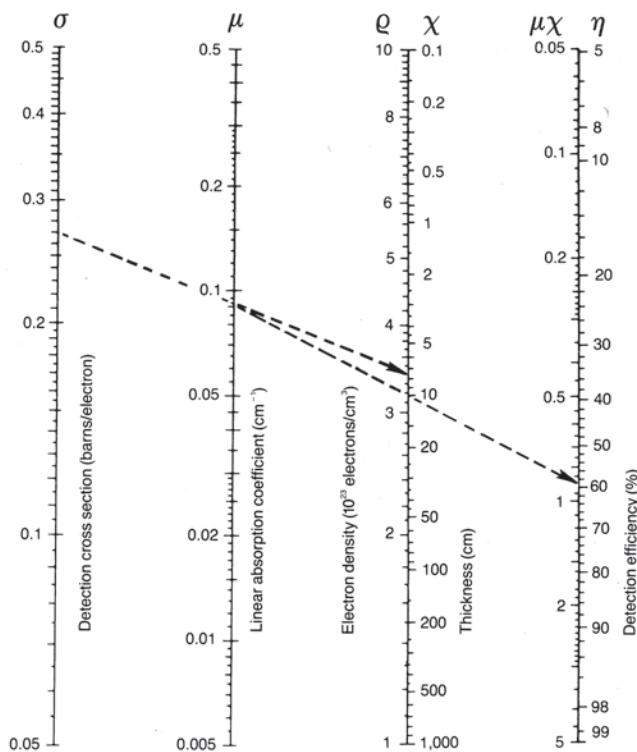

Fig. 2. Gamma detection efficiency nomogram.

PRODUCT APPLICATIONS AND COMMERCIAL EQUIVALENTS

MATERIAL	DESCRIPTION/APPLICATION	COMMERCIAL EQUIVALENT		PAGE
		NE	S-G	
PLASTIC SCINTILLATORS				
EJ-200	Best overall general properties	Pilot F	BC-408	4
EJ-204	Good general properties, Use with green WLS	NE-104	BC-404	4
EJ-208	Good general properties, High attenuation length	NE-110	BC-412	4
EJ-212	Good general properties, Thin films	NE-102A	BC-400	4
EJ-214	Ultra-thin films (25 µm), Formerly EJ-299-07	-	-	6
EJ-228	Very fast timing, High pulse pair resolution, Small sizes (< 10 cm)	Pilot U	BC-418	7
EJ-230	Variant of EJ-228, Used for detector dimensions exceeding 10 cm	Pilot U2	BC-420	7
EJ-232	Very fast timing, Use with blue WLS, Small sizes (< 10 cm)	NE-111A	BC-422	8
EJ-232Q	Variant of EJ-232, Quenched for ultra-fast timing	-	BC-422Q	8
EJ-240	Long decay time	NE-115	BC-444	9
EJ-244	Elevated temperature, Analog to EJ-208, General purpose	-	BC-440	10
EJ-244M	Variant of EJ-244, Crosslinked	-	BC-440M	10
EJ-248	Elevated temperature, Analog to EJ-200, General purpose	-	BC-448	10
EJ-248M	Variant of EJ-248, Crosslinked	-	-	10
EJ-254	Boron loaded	-	BC-454	12
EJ-256	Lead loaded, X-rays, Dosimetry	NE-142	BC-452	13
EJ-260	Green-emitting, Solid-state sensors	NE-103	BC-428	15
EJ-262	Green-emitting, Solid-state sensors	-	-	15
EJ-270	⁶ Lithium loaded PSD plastic, Fast neutron-gamma discrimination	-	-	16
EJ-276D	PSD plastic, Fast neutron-gamma discrimination	-	-	18
EJ-276G	PSD plastic, Fast neutron-gamma discrimination, Green-emitting	-	-	18
EJ-290	Scintillator casting resin, General purpose	NE-120	BC-490	19
EJ-296	Scintillator paint, Used to make thin films	-	BC-498	20
LIQUID SCINTILLATORS				
EJ-301	PSD liquid, Fast neutron-gamma discrimination	NE-213	BC-501A	29
EJ-309	PSD liquid, Fast neutron-gamma discrimination, High flash point, Low chemical toxicity, Compatible with acrylic plastics	-	-	29
EJ-309B	Variant of EJ-309 with natural boron loading	-	-	30
EJ-313	Hydrogen-free, Neutron studies	NE-226	BC-509	31
EJ-315	Deuterated benzene, Neutron studies	NE-230	BC-537	32
EJ-321L	Mineral oil based, Large tanks, Fast neutron and gamma, Cosmics	NE-235L	BC-517L	33
EJ-321H	Mineral oil based, Large tanks, High light output, PSD, Fast neutron and gamma discrimination	NE-235H	BC-517H	33
EJ-321P	Mineral oil based, High flash point, Safe to use with gray PVC plastic	-	BC-517P	33
EJ-321S	Mineral oil based, Highest light output of EJ-321 series	-	BC-517S	33
EJ-325A	Mineral oil based, PSD, Fast neutron and gamma discrimination	NE-235C	BC-519	34
EJ-331	Gd loaded, High light output, Fast neutrons, Neutrinos	NE-323	BC-521	35
EJ-335	Gd loaded, Mineral oil based, Large tanks, Fast neutrons, Neutrinos	-	BC-525	35
EJ-351	Dioxane based cocktail for aqueous samples	NE-220	BC-573	36

MATERIAL	DESCRIPTION/APPLICATION	COMMERCIAL EQUIVALENT		PAGE
		NE	S-G	
WAVELENGTH SHIFTERS				
EJ-280	Green-emitting wavelength shifting plastic	-	BC-482A	22
EJ-282	Green-emitting wavelength shifting plastic	-	-	22
EJ-284	Red-emitting wavelength shifting plastic	-	-	22
EJ-286	Blue-emitting wavelength shifting plastic	-	BC-480	22
EJ-298	Blue-emitting wavelength shifting paint, Thin films	-	-	24
EJ-298G	Green-emitting wavelength shifting paint, Thin films	-	-	24
PLASTIC FIBERS				
EJ-100	Blue-emitting scintillating fiber	-	-	26
EJ-104	Blue-emitting scintillating fiber	-	-	26
EJ-108	Blue-emitting scintillating fiber	-	-	26
EJ-160	Green-emitting scintillating fiber	-	-	26
EJ-162	Green-emitting scintillating fiber	-	-	26
EJ-180	Green-emitting wavelength shifting fiber	-	-	26
EJ-182	Blue/Green-emitting wavelength shifting fiber	-	-	26
EJ-184	Red-emitting wavelength shifting fiber	-	-	26
EJ-186	Blue-emitting wavelength shifting fiber	-	-	26
ACRYLIC PLASTIC				
PMMA	Clear acrylic plastic, Light guides	-	BC-802	27
UVT	UV transmitting acrylic plastic, Light guides	-	BC-800	27
NEUTRON DETECTORS				
EJ-410	Fast neutron detector	NE-451	BC-720	39
EJ-420	Thermal neutron detector	NE-422	BC-702	40
EJ-426	Thermal neutron detector sheet	-	-	41
ZINC SULFIDE COATED				
EJ-440	ZnS:Ag coated 0.25 mm thick polyester sheets and discs, Alphas	-	-	43
EJ-442	ZnS:Ag coated acrylic plastic or glass, Alphas	-	-	43
EJ-444	ZnS:Ag coated EJ-212 plastic scintillator, Alphas and betas	-	-	44
EJ-600	ZnS:Ag phosphor powder	-	-	45
ACCESSORIES				
EJ-500	Optical cement	NE-580	BC-600	47
EJ-510	White reflector paint for plastics	NE-560	BC-620	48
EJ-550	Optical grade silicone grease	-	BC-630	49
EJ-552	General purpose silicone grease	-	-	49
EJ-554	Black vinyl tape	-	BC-638	49
EJ-556	Protective adhesive paper masking	-	BC-640	49
EJ-558	Protective adhesive transparent plastic masking	-	-	49
EJ-560	Silicone rubber optical interface	-	BC-634A	50

WARRANTY STATEMENT

Unless otherwise agreed, the Seller (Eljen Technology) guarantees to the original Buyer, at the Seller's discretion, to repair or replace those products which proved to the Seller's reasonable satisfaction not to conform to the published specifications at the time of receipt by the Buyer or to have failed by reason of faulty design or workmanship during a period of 12 months following the date of shipment.

HEADQUARTERS AND MANUFACTURING



Eljen Technology

1300 W. Broadway
Sweetwater, Texas 79556
Tel: (325) 235-4276
Tel (Toll Free): (888) 800-8771
Fax: (325) 235-0701
Email: eljen@eljentechnology.com
Website: eljentechnology.com

INTERNATIONAL REPRESENTATIVES AND DEALERS

EUROPE (excluding UK)

Scionix Holland BV
Bunnik, The Netherlands
Tel: +31 (0)30 6570312
Email: scionix@scionix.nl
Website: scionix.nl

UNITED KINGDOM

Phoenix Dosimetry Ltd.
Sandhurst, Berkshire, United Kingdom
Tel: 44 (0)1252 871990
Email: sales@phoenix-dosimetry.co.uk
Website: phoenix-dosimetry.co.uk

CHINA

**Beijing Wahenyida Science and
Technology Development Co. Ltd.**
Beijing, P.R. China
Tel: (8610) 88258671
Fax: (8610) 88696193
Email: sales@wahenyida.com
Website: www.wahenyida.com

JAPAN

G-Tech, Corp.
Iruma, Saitama, Japan
Tel: 81-(0)429-35-2777
Fax: 81-(0)429-35-2778
Email: goto@ggg-tech.co.jp

INDIA

Electronic Enterprises Private Limited
Mumbai, India
Tel/Fax: 91 2224133341
Email: sahasrab@vsnl.com

CAEN spa India Private Limited

Mumbai, India
Email: sales@caen-india.in
Web: www.caen-india.in

SOUTH KOREA

NEOSISKOREA Co., Ltd.
Daejon, Korea
Tel: 82-42-489-6541-2
Fax: 82-42-489-6534
Email: info@neosiskorea.com

Saram International Co., Ltd.

Seoul, Korea
Tel: 82-2-3402-0518
Email: june.yoo@sa-ram.com
Web: www.sa-ram.com