

# LIQUID SCINTILLATOR CELLS AND DETECTOR ASSEMBLIES

Our liquid scintillators are available encapsulated within either aluminum or glass cells with a clear window for coupling to a photomultiplier tube. The most common model is a cylindrical aluminum cell with one window and a mounting flange. Both cells with an expansion void bubble and bubble-free cells are offered. Standard sizes are 51 mm (2") dia., 76 mm (3") dia., and 127 mm (5") dia. regular cylinders. Custom sizes are also available. Aluminum liquid scintillator cells can also be supplied with a photomultiplier tube as a complete detector assembly. Assemblies include a photomultiplier tube, voltage divider, Mu-shielding and light-tight housing.

## Expansion Void Cell With Flange

### VMF-D×H Liquid Scintillator Cell

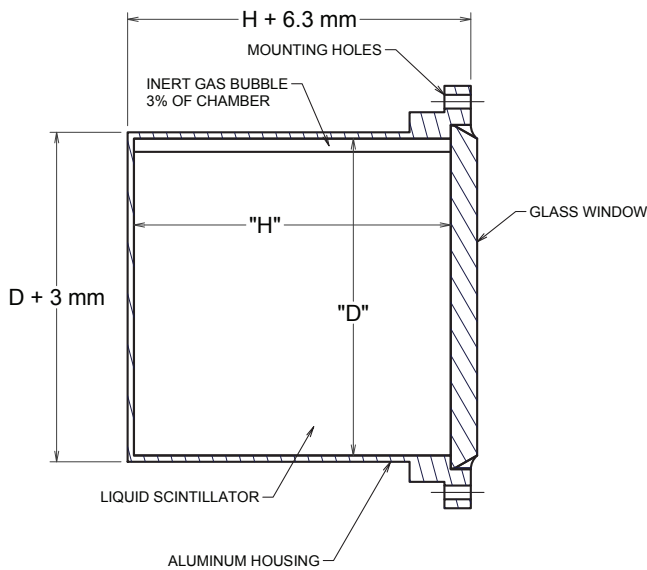

## Bubble-Free Cell With Flange

### BFF-D×H Liquid Scintillator Cell

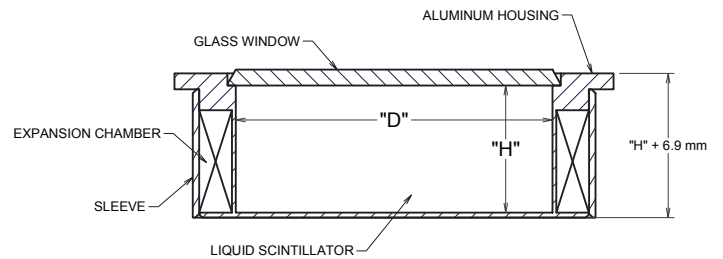

## M510-30×30 (3" Dia.) Liquid Scintillator Detector Assembly

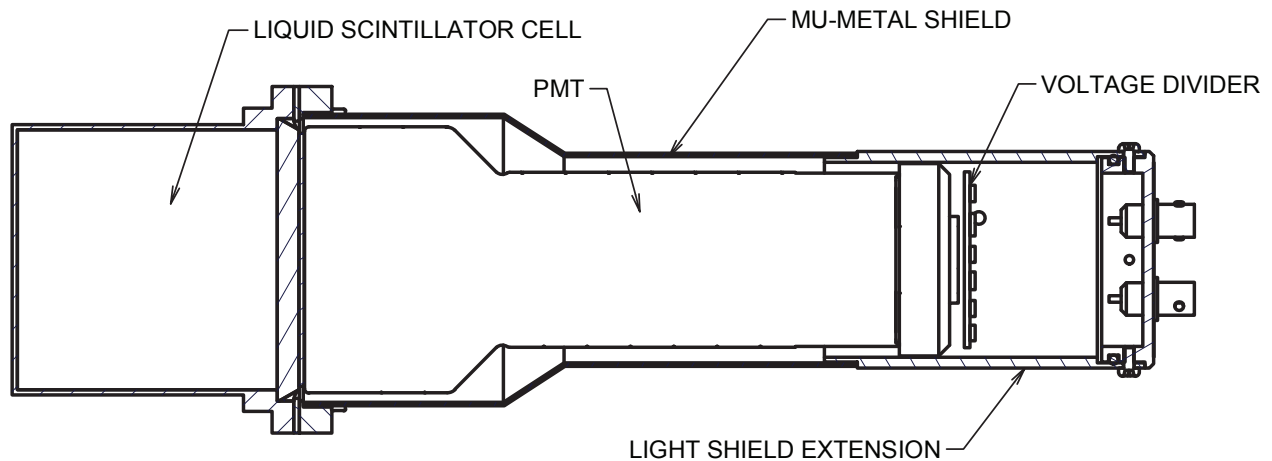

Revision Date: Jul 2021



**ELJEN TECHNOLOGY**

1300 W. Broadway, Sweetwater, TX 79556

www.eljentechnology.com • eljen@eljentechnology.com

Toll Free (USA): (888)-800-8771 • Tel: (325)-235-4276 • Fax: (325) 235-0701

